

# VILLAGE OF JOHNSBURG EAST SERVICE AREA PHASE 1 SANITARY SEWER EXTENSION

**OWNER:**  
VILLAGE OF JOHNSBURG  
1515 CHANNEL BEACH AVENUE  
JOHNSBURG, ILLINOIS 60051  
PHONE: (815) 385-6023

**ENGINEER / SURVEYOR CONTACT:**  
HR GREEN INC.,  
420 S. FRONT ST.  
MCHENRY IL. 60050  
PHONE: (815) 385-1778  
TIMOTHY J. HARTNETT – VILLAGE ENGINEERING CONSULTANT  
SEAN G. MURPHY, P.E. – PROJECT MANAGER  
CHAD PIEPER, P.E. – CONSTRUCTION MANAGER  
DOUG STALKER, PROJECT SURVEYOR

**JOHNSBURG, ILLINOIS  
MCHENRY TOWNSHIP, MCHENRY COUNTY  
SECTION 18, TOWNSHIP 45 NORTH, RANGE 9 EAST AND  
SECTION 13, TOWNSHIP 45 NORTH, RANGE 8 EAST**

**PLANS PREPARED FOR:  
VILLAGE OF JOHNSBURG  
1515 CHANNEL BEACH AVENUE  
JOHNSBURG, ILLINOIS 60051**

**PROJECT CONTACT:  
MS. CLAUDETT SOFIAKIS - VILLAGE ADMINISTRATOR  
PHONE: (815) 385-6023**

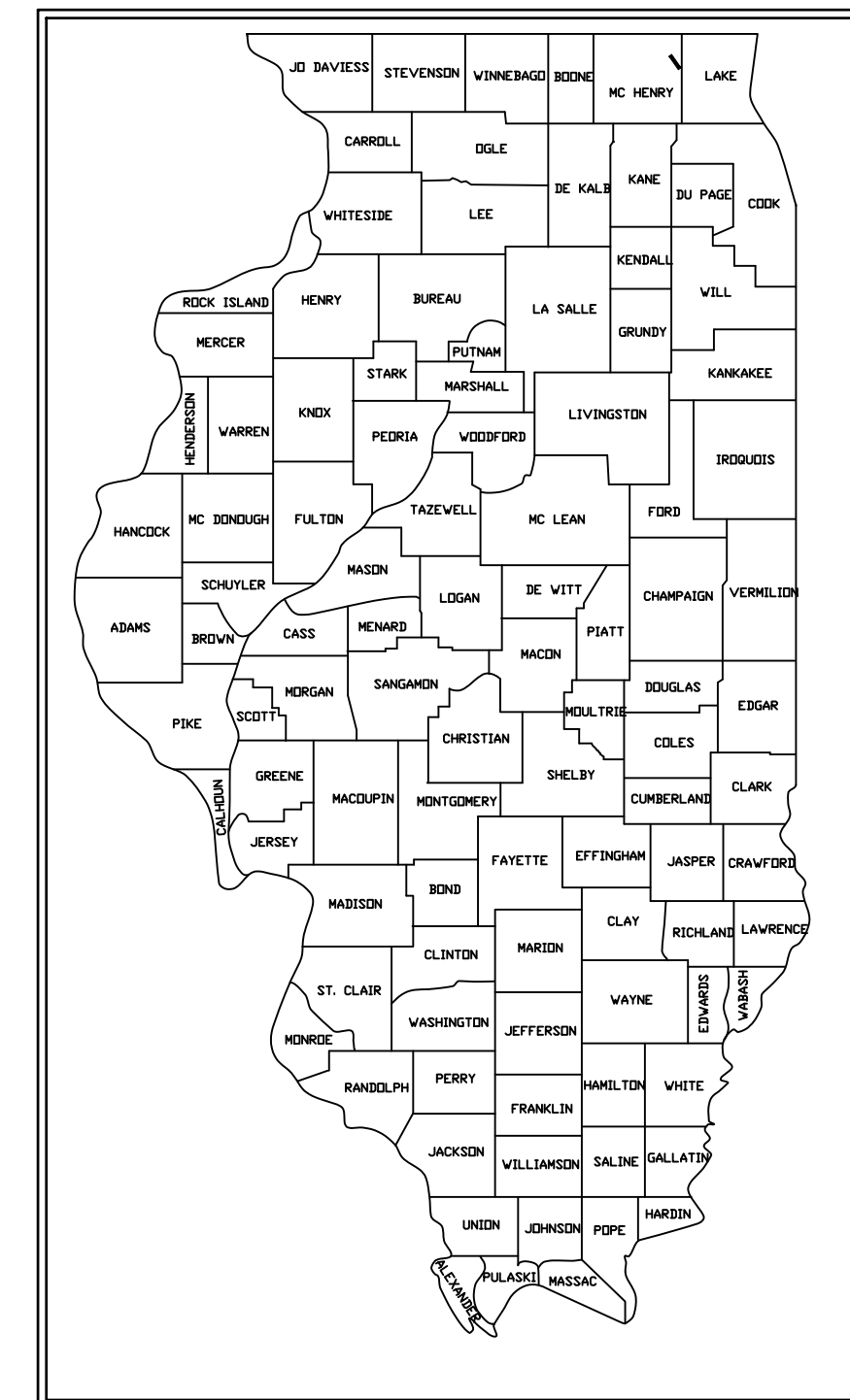

## Sheet List Table

Sheet Number	Sheet Title
CG001	Cover Sheet
CG002	General Notes and Specs
CG003	General Notes and Specs
CG004	General Notes and Specs
CG100	Overall Key Map
CG101	Traffic Control Plan
CU100	Gravity Sewer Main Plan & Profile
CU101	Gravity Sewer Main Plan & Profile (Omitted)
CU102	Gravity Sewer Main Plan & Profile (A)
CU103	Gravity Sewer Main Plan & Profile
CU200	Force Main Plan & Profile
CU201	Force Main Plan & Profile
CU202	Force Main Plan & Profile
CU300	Lift Station – Site Plan
CU301	Lift Station – Typical Section
CU302	Lift Station – Details
CU400	Standard Details
CU401	Standard Details
CU402	Standard Details
CU403	Standard Details
CU404	Standard Details
CU405	Standard Details

(A) = ALTERNATE BID SHEET

## SITE LOCATION MAP

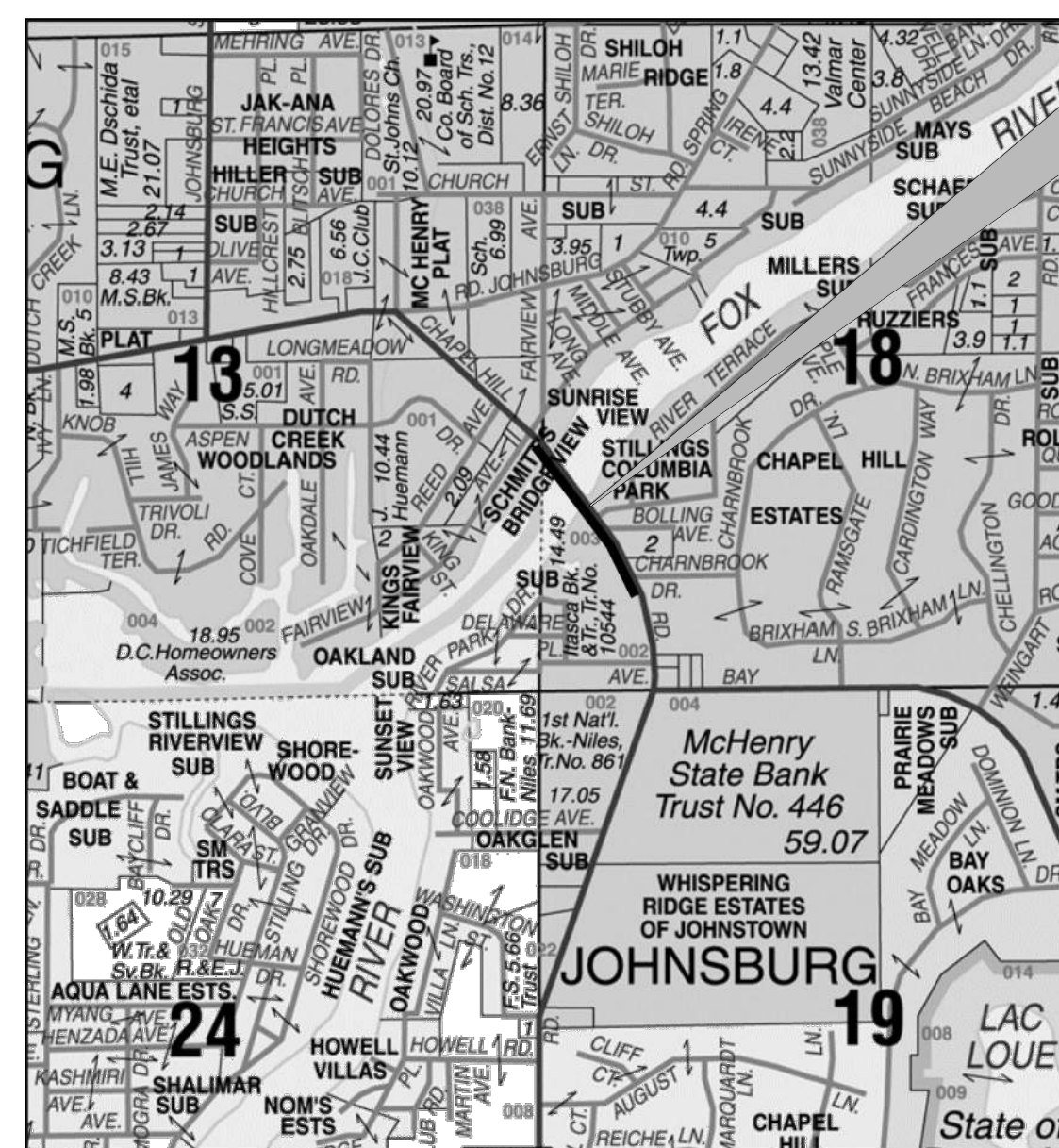

- NOTE:**
- HR GREEN, INC. IS TO BE NOTIFIED 3 DAYS PRIOR TO CONSTRUCTION START.
  - MCHENRY COUNTY DOT IS TO BE NOTIFIED 2 DAYS PRIOR TO CONSTRUCTION START.
  - HR GREEN, INC. SHALL BE INCLUDED IN ALL PRE-CONSTRUCTION MEETINGS.
  - ANY KNOW DISCREPANCIES ON THIS PLAN SET MUST BE BROUGHT TO THE ATTENTION OF HR GREEN, INC. PRIOR TO THE START OF CONSTRUCTION.

Dial 811 or 1-800-892-0123



Know what's below.  
Call before you dig.

WITH THE FOLLOWING:  
COUNTY MCHENRY COUNTY  
CITY-TOWNSHIP JOHNSBURG – MCHENRY TOWNSHIP  
SEC. & 1/4 SEC. NO. # 7 & 18-45-9

Two (2) working days before you dig  
(Excluding Sat., Sun. & Holidays)

### BENCHMARKS:

BENCHMARK 1:  
RAILROAD SPIKE IN THE NORTH FACE OF WOOD POWER POLE LOCATED AT THE SOUTHEAST CORNER OF FAIRVIEW AVENUE AND JOHNSBURG ROAD.  
ELEVATION=757.53 NAVD88

BENCHMARK 2:  
RAILROAD SPIKE IN NORTH FACE OF POWER POLE LOCATED AT THE SOUTH SIDE OF ROAD IN FRONT OF 2113 FAIRVIEW AVE.  
ELEV=741.69 (NAVD88)



420 N. FRONT STREET, SUITE 100 | MCHENRY, IL 60050  
Phone: 815.385.1778 | Toll Free: 800.728.7805 | Fax: 815.385.1781 | HRGreen.com

DRAWN BY: HCM JOB DATE: 2022  
APPROVED: SGM JOB NUMBER: 210915  
CAD DATE: 1/8/2024  
CAD FILE: \\hrgreen.com\HRG\Data\2021\210915\CAD\Dwgs\C

BAR IS ONE INCH ON OFFICIAL DRAWINGS.  
IF NOT ONE INCH, ADJUST SCALE ACCORDINGLY.

NO.	DATE	BY	REVISION DESCRIPTION
1	1/5/24	NF	ADDENDUM #3

ILLINOIS DESIGN FIRM # 184.001322  
1391 CORPORATE DRIVE, SUITE 203  
MCHENRY, ILLINOIS 60050  
PHONE: 815.385.1778 | TOLL FREE: 800.728.7805  
FAX: 815.385.1781 | HRGreen.com

EAST SERVICE AREA PHASE 1  
SANITARY SEWER EXTENSION  
VILLAGE OF JOHNSBURG  
JOHNSBURG, ILLINOIS

COVER SHEET

SHEET NO.  
CG001

ADDENDUM #3 FOR BID

# GENERAL NOTES & SPECIFICATIONS

## 1. SPECIFICATIONS, STANDARDS AND SPECIAL PROVISIONS

ALL CONSTRUCTION SHALL BE DONE IN ACCORDANCE WITH THE LATEST EDITION IN EFFECT ON THE DATE OF INVITATION FOR BIDS, OF THE FOLLOWING:

"STANDARD SPECIFICATIONS FOR ROAD AND BRIDGE CONSTRUCTION", BY THE ILLINOIS DEPARTMENT OF TRANSPORTATION, HEREINAFTER REFERRED TO AS THE "STANDARD SPECIFICATIONS";

"SUPPLEMENTAL SPECIFICATIONS AND RECURRING SPECIAL PROVISIONS", BY THE ILLINOIS DEPARTMENT OF TRANSPORTATION;

"ILLINOIS MANUAL ON UNIFORM TRAFFIC CONTROL DEVICES FOR STREETS & HIGHWAYS";

"STANDARD SPECIFICATIONS FOR WATER & SEWER MAIN CONSTRUCTION IN ILLINOIS";

VILLAGE OF JOHNSBURG "SUBDIVISION ORDINANCE" AND "ENGINEERING STANDARDS";

THESE PLANS AND THE "SPECIAL PROVISIONS" \* INCLUDED IN THE CONTRACT DOCUMENTS.

\* THESE SPECIAL PROVISIONS SUPPLEMENT THE ABOVE SPECIFICATIONS, AND IN CASE OF CONFLICT WITH ANY PART OR PARTS OF SAID SPECIFICATIONS, THESE SPECIAL PROVISIONS SHALL TAKE PRECEDENCE AND SHALL GOVERN.

## 2. COORDINATION WITH UTILITIES

PRIOR TO THE START OF CONSTRUCTION, THE CONTRACTOR SHALL HAVE ALL UTILITIES LOCATED BY J.U.L.I.E (1-800-892-0123). THE CONTRACTOR SHALL COOPERATE WITH ALL UTILITY OWNERS AS PROVIDED FOR IN THE STANDARD SPECIFICATIONS.

THE CONTRACTOR SHALL BE RESPONSIBLE FOR THE PROTECTION OF ALL UNDERGROUND OR SURFACE UTILITIES, EVEN THOUGH THEY MAY NOT BE SHOWN ON THE PLANS. ANY UTILITY THAT IS DAMAGED DURING CONSTRUCTION SHALL BE REPAIRED OR REPLACED TO THE SATISFACTION OF THE ENGINEER OR THE OWNER. THIS WORK SHALL BE PAID FOR AT THE CONTRACTOR'S EXPENSE.

IT IS THE CONTRACTOR'S RESPONSIBILITY TO LOCATE ALL EXISTING UTILITIES PRIOR TO CONSTRUCTION. THE LOCATION OF EXISTING UTILITIES AS SHOWN ON THESE PLANS IS BASED ON RECORD INFORMATION AND MAY NOT BE ACCURATE. WHERE CONFLICT EXISTS BETWEEN EXISTING UTILITIES AND THE PROPOSED UNDERGROUND PIPING REQUIRING A REVISION TO THE PLANS, SUCH CONSTRUCTION SHALL NOT BE UNDERTAKEN UNTIL SUCH CHANGES ARE APPROVED BY THE ENGINEER. THE CONTRACTOR SHALL REPORT ALL SUCH CONFLICTS IMMEDIATELY TO THE ENGINEER.

ALL EXISTING UTILITIES WITHIN THE PROJECT AREA SHALL BE REMOVED AND RELOCATED, IF NECESSARY, FOR CONSTRUCTION BY THE UTILITY COMPANY WHICH HAS JURISDICTION OVER IT. THE CONTRACTOR IS RESPONSIBLE FOR SCHEDULING WITH THE APPROPRIATE UTILITY COMPANY.

WHERE PROPOSED UTILITY CROSSES UNDER EXISTING GAS MAIN THE CONTRACTOR SHALL PROVIDE EXTRA CARE WHEN INSTALLING PROPOSED UTILITY TO PREVENT DAMAGE TO EXISTING GAS MAIN.

THE COORDINATION OF ALL UTILITY WORK FOR THE CONSTRUCTION PROJECT SHALL BE DISCUSSED AT A PRE CONSTRUCTION MEETING.

CONTRACTOR IS RESPONSIBLE FOR PROTECTION AND REPAIR OF ALL PRIVATE AMENITIES (I.E. INVISIBLE DOG FENCES, IRRIGATION SYSTEMS, ETC.) THAT ARE IN CONFLICT WITH PROPOSED PROJECT WORK. THIS WORK SHALL BE INCLUDED IN THE UNIT COST AS BID FOR WORK ITEM IMPACTING SYSTEM.

## 3. STAKING

THE CONTRACTOR SHALL PROTECT AND CAREFULLY PRESERVE ALL SECTION OR SUBSECTION MONUMENTS OR PROPERTY OR REFERENCE MARKERS UNTIL THE OWNER, HIS AGENT OR AN AUTHORIZED SURVEYOR HAS WITNESSED OR OTHERWISE REFERENCED THEIR LOCATIONS.

ALL OFFSET LOCATIONS GIVEN ON THE DETAILED PLANS FOR STRUCTURES, FITTINGS, ETC., ARE FROM THE CENTERLINE OF THE EXISTING ROADWAY, AS SHOWN ON THESE PLANS.

ALL ELEVATIONS ARE ON U.S.G.S. DATUM. (NAVD 88).

## 4. EROSION CONTROL & LANDSCAPE RESTORATION

TREES INDICATED TO BE PROTECTED SHALL BE BORED/TUNNELED OR SHALL HAVE ROOT PRUNING DONE AS NECESSARY. ALL ROOT PRUNING MUST BE APPROVED BY THE OWNER'S APPOINTED REPRESENTATIVE. THE CONTRACTOR SHALL TAKE CARE IN GRADING NEAR TREES, SHRUBS AND BUSHES WHICH ARE NOT TO BE REMOVED SO AS NOT TO CAUSE INJURY TO THE ROOTS, TRUNKS OR LIMBS. THIS WORK SHALL BE CONSIDERED INCIDENTAL TO THE REMOVAL WORK BEING PERFORMED.

LANDSCAPING INCLUDING, BUT NOT LIMITED TO TREES, SHRUBS, BUSHES, RETAINING WALLS, DECORATIVE LANDSCAPING ITEMS, ETC., LOCATED IN THE DISTURBED AREA, AS INDICATED ON THE PLANS, SHALL BE RESTORED BY THE CONTRACTOR TO THE SATISFACTION OF THE ENGINEER. THIS WORK SHALL BE CONSIDERED INCIDENTAL TO THE ITEM OF WORK BEING PERFORMED.

THE CONTRACTOR SHALL MAKE EVERY EFFORT TO AVOID DISTURBING ANY EXISTING RESIDENTIAL LANDSCAPING, LANDSCAPING APPURTENANCES, WALKWAYS,

RETAINING WALLS, ETC., THAT ARE NOT MARKED FOR REMOVAL ON THE PLANS. IF DAMAGE OCCURS, THE CONTRACTOR SHALL REPLACE, IN KIND, THE RESIDENTIAL ITEM OR ITEMS AT HIS/HER EXPENSE IN A MANNER MEETING WITH THE APPROVAL OF THE ENGINEER. ALL VEGETATION BEING REMOVED SHALL BE REPLACED WITH THE SAME SIZE AND TYPE. NO ADDITIONAL COMPENSATION WILL BE ALLOWED FOR DAMAGED ITEMS.

IT SHALL BE THE CONTRACTOR'S RESPONSIBILITY TO PROPERLY CONTROL EROSION ON THE JOB SITE THROUGH THE USE OF SILTATION PONDS, FILTER FABRICS, ETC. ANY SILTATION OF CONDUITS, STRUCTURES, OR DITCHES SHALL BE CLEANED AND MAINTAINED BY THE CONTRACTOR UNTIL ANY SEEDING AND/OR SODDING HAS TAKEN HOLD. ALL WASHOUTS, GULLIES, ETC. WILL BE REGRADED AND RESODDED BY THE CONTRACTOR. ALL MAINTENANCE & CLEANING OF EROSION CONTROL ITEMS SHALL BE INCLUDED IN THE COST OF PAY ITEM.

FOR ALL DRAINAGE STRUCTURES IN THE DISTURBED AREAS, INLET FILTERS SHALL BE PLACED BETWEEN FRAME AND GRATE AND MAINTAINED BY THE CONTRACTOR UNTIL VEGETATION IS ESTABLISHED, AS DETERMINED BY THE VILLAGE.

THE CONTRACTOR'S RESPONSIBILITY FOR EROSION CONTROL SHALL EXTEND THROUGHOUT THE CONSTRUCTION PROCESS. THE CONTRACTOR SHALL BE RESPONSIBLE FOR CLEANUP OF PAVED SURFACES DAILY WITHIN AND OUTSIDE OF THE PROJECT CAUSED BY THE CONTRACTOR.

EROSION CONTROL STRUCTURES MUST BE INSPECTED WEEKLY AND AFTER EVERY STORM OF ONE HALF INCH (1/2") OF RAINFALL OR GREATER, BY THE CONTRACTOR. AN INSPECTION REPORT MUST BE SUBMITTED BY THE CONTRACTOR TO THE VILLAGE FOLLOWING EACH INSPECTION. ANY REPAIRS OR REPLACEMENT NEEDED TO ENSURE ADEQUATE EROSION CONTROL MUST BE MADE IMMEDIATELY AT THE CONTRACTOR'S EXPENSE.

ONCE THE UNDERGROUND UTILITY INSTALLATION HAS BEEN COMPLETED, ALL DISTURBED AREAS ARE TO BE GRADED TO EXISTING CONTOURS AND TO PROVIDE POSITIVE DRAINAGE TO PROPOSED AND EXISTING DRAINAGE STRUCTURES UNLESS OTHERWISE NOTED ON PLANS.

FINAL GRADE SHALL MEET EXISTING GRADE AND SHALL BE OF AT LEAST 4" TOPSOIL. ALL GRADING ASSOCIATED WITH UNDERGROUND UTILITY REMOVAL, INSTALLATION AND CONSTRUCTION SHALL BE CONSIDERED INCLUDED IN THE COST OF SEWER MAIN CONSTRUCTION AND RESTORATION.

## 5. TRAFFIC CONTROL AND PROTECTION

ALL TRAFFIC CONTROL AND OTHER ADVISORY SIGNS NEEDED FOR CONSTRUCTION ARE TO BE FURNISHED BY THE CONTRACTOR IN ACCORDANCE WITH ARTICLE 107.14 OF THE STANDARD SPECIFICATIONS.

IF NEEDED, ANY EXISTING TRAFFIC REGULATORY AND STREET SIGNS WITHIN THE LIMITS OF THE CONSTRUCTION SHALL BE REMOVED AND STORED BY THE CONTRACTOR. APPROPRIATE TRAFFIC REGULATORY AND STREET SIGNS SHALL BE INSTALLED BY THE CONTRACTOR AS SOON AS CONSTRUCTION ACTIVITIES PERMIT.

ALL UNBALLASTED TYPE I AND TYPE II BARRICADES SHALL HAVE TWO SANDBAGS ON THE BOTTOM RAIL.

CONTRACTOR SHALL PROVIDE "BUMP" SIGNAGE AT EACH ENTRANCE TO WORK ZONE.

## 6. MISCELLANEOUS

THE CONTRACTOR SHALL NOTIFY THE VILLAGE OF JOHNSBURG, COUNTY OF McHENRY, AND THE RESIDENTS WITHIN THE PROJECT LIMITS A MINIMUM OF 48 HOURS PRIOR TO THE START OF CONSTRUCTION.

DURING CONSTRUCTION, THE CONTRACTOR SHALL PROVIDE ACCESS TO ALL ABUTTING PROPERTIES, EXCEPT FOR PERIODS OF SHORT DURATION AS APPROVED BY THE ENGINEER. ANY ROADWAY OR ACCESS CLOSURES SHALL ONLY TAKE PLACE BETWEEN THE HOURS OF 10:00 A.M. AND 3:00 P.M. THE VILLAGE OF JOHNSBURG SHALL BE NOTIFIED 24 HOURS IN ADVANCE OF ANY CLOSURES. CHAPEL HILL ROAD SHALL NOT BE CLOSED WITHOUT EXPRESS PRIOR WRITTEN PERMISSION OF McDOT. THIS WORK SHALL BE INCLUDED AND PAID FOR AS "TRAFFIC CONTROL AND PROTECTION."

ALL WORK PERFORMED RELATIVE TO THIS IMPROVEMENT SHALL COMPLY WITH ALL APPLICABLE RULES AND REGULATIONS OF O.S.H.A.

ALL CONSTRUCTION PERSONNEL WILL BE REQUIRED TO WEAR A SAFETY VEST AND ANY OTHER SAFETY EQUIPMENT REQUIRED TO COMPLY WITH THE LATEST O.S.H.A. REQUIREMENTS, AT ALL TIMES WHILE AT THE CONSTRUCTION SITE. COMPLIANCE WITH THIS REQUIREMENT SHALL BE CONSIDERED AS INCIDENTAL TO THE CONTRACT.

SAW CUTTING IS REQUIRED FOR ALL PAVEMENT REMOVAL IS INCLUDED IN THE COST OF REMOVAL AND REPLACEMENT.

ALL TRENCHES SHALL BE BACKFILLED OR COVERED AT THE END OF EACH DAY OF CONSTRUCTION.

REMOVE EXISTING TREES AND BUSHES AS NECESSARY FOR CONSTRUCTION AND ONLY AS APPROVED BY THE VILLAGE. REPLACEMENT WILL BE PER VILLAGE ORDINANCE.

THE CONTRACTOR SHALL REMOVE ALL MAILBOXES WITHIN THE LIMITS OF CONSTRUCTION WHICH INTERFERE WITH CONSTRUCTION OPERATIONS AND ERECT THEM AT TEMPORARY LOCATIONS AS APPROVED BY THE ENGINEER. AS SOON AS CONSTRUCTION OPERATION PERMITS, THE CONTRACTOR SHALL SET THE MAILBOXES AT THEIR PERMANENT LOCATIONS. THIS WORK SHALL BE CONSIDERED INCIDENTAL TO THE ITEM OF WORK BEING PERFORMED. THE CONTRACTOR SHALL REPLACE, AT HIS/HER EXPENSE, ANY MAILBOX OR POST WHICH HAS BEEN DAMAGED DURING CONSTRUCTION. NO ADDITIONAL COMPENSATION SHALL BE ALLOWED.

NO PLANS SHALL BE USED FOR CONSTRUCTION UNLESS SPECIFICALLY MARKED "FOR CONSTRUCTION." PRIOR TO COMMENCEMENT OF CONSTRUCTION, THE CONTRACTOR SHALL VERIFY ALL DIMENSIONS AND CONDITIONS AFFECTING THEIR WORK WITH THE ACTUAL CONDITIONS AT THE JOB SITE. IN ADDITION, THE CONTRACTOR MUST VERIFY THE LINE AND GRADE STAKES. IF THERE ARE ANY DISCREPANCIES FROM WHAT IS SHOWN ON THE CONSTRUCTION PLANS, HE/SHE MUST IMMEDIATELY REPORT SAME TO THE ENGINEER BEFORE DOING ANY WORK, OTHERWISE THE CONTRACTOR ASSUMES FULL RESPONSIBILITY. IN THE EVENT OF A DISAGREEMENT BETWEEN THE CONSTRUCTION PLANS, STANDARD SPECIFICATIONS AND/OR SPECIAL DETAILS, THE CONTRACTOR SHALL SECURE WRITTEN INSTRUCTIONS FROM THE ENGINEER PRIOR TO PROCEEDING WITH ANY PART OF THE WORK AFFECTED BY OMISSIONS OR DISCREPANCIES. FAILING TO SECURE SUCH INSTRUCTIONS, THE CONTRACTOR WILL BE CONSIDERED TO HAVE PROCEEDED AT HIS/HER OWN RISK AND EXPENSE. IN THE EVENT OF ANY DOUBT OR QUESTION RISING WITH RESPECT TO THE TRUE MEANING OF THE CONSTRUCTION PLANS OR SPECIFICATIONS, THE DECISION OF THE ENGINEER SHALL BE FINAL AND CONCLUSIVE.

## 7. MATERIALS PERMITTED FOR USE IN SANITARY SEWERS ARE AS FOLLOWS. SANITARY SEWER MATERIAL SHALL NOT BE SWITCHED BETWEEN MANHOLES.

DIP CLASS 52 ANSI A-21.51, PUSH ON ANSI A-21.11 JOINTS AND ANSI A21.11 STYRENE BUTADIENE - SBR RUBBER GASKETS.

PSM PVC SDR 26 ASTM D-3034 WITH ASTM D3212 JOINTS

PSM PVC DR 18, 150 PSI RING-TITE, AWWA C-900, WITH ASTM D-3139 JOINTS AND ASTM F-477 ELASTOMERIC RUBBER RING GASKETS, AND MINIMUM PIPE STIFFNESS OF 375 PSI

SERVICES TO MATCH SEWER MAIN.

JOINTS: GRAVITY SEWER: BELL AND SPIGOT WITH ELASTOMERIC SEALS CONFORMING TO ASTM D-3212 OR ASTM 3139 WHICHEVER IS APPLICABLE, AND GASKETS TO ASTM F-477.

SANITARY SEWER FORCE MAIN MATERIAL SHALL MEET THE SPECIFICATIONS OF DUCTILE IRON FITTINGS, AND DUCTILE IRON WATERMAIN, HDPE DR11 ANSI/AWWA C906, ASTM D-3350, OR PVC C900 DR18 (WITH TRACE WIRE).

DETECTABLE TRACER WIRES: T304 COATED STAINLESS STEEL AIRCRAFT CABLE SIZED TO WITHSTAND PUSH REQUIRED, BUT AT A MINIMUM OF 3/16" DIAMETER. TERMINAL ENDS TO BE PLACED IN ALL STRUCTURES, WITH A 5' LOOP OF WIRE SECURED TO A STAINLESS STEEL HOOK MOUNTED INSIDE THE STRUCTURE. ALL TRACER WIRE SPLICES SHALL BE MADE WITH WATER TIGHT ELECTRICAL CONNECTIONS DRYRUNN DIRECT BURY LUG, SPLIT BOLT TYPE OR ENGINEER APPROVED EQUAL TRACER WIRE AND CONNECTORS SHALL BE CONSIDERED INCIDENTAL TO THE ITEM OF WORK BEING PERFORMED.

## 8. SANITARY MANHOLE TYPE A

MANHOLES SHALL BE CONSTRUCTED OF PREFABRICATED CONCRETE SECTIONS MEETING THE REQUIREMENTS OF ASTM C-478. SECTIONS SHALL BE JOINED USING EITHER FLEXIBLE RUBBER GASKETS OR PREFORMED BITUMINOUS PLASTIC GASKETS. THE MANHOLE BOTTOM SHALL BE PRECAST WITH THE FIRST RISER SECTION. MANHOLES SHALL HAVE THE PIPE CAST IN PLACE THROUGH THE MANHOLE OR A WATERTITE JOINT CAST IN THE MANHOLE WALL TO RECEIVE THE PIPE. ALL MANHOLES SHALL BE TESTED FOR WATERTIGHTNESS IN ACCORDANCE WITH ASTM C1244-93. PROVIDE PRECAST CONCRETE MANHOLE WITH EXTERIOR BITUMINOUS COATING AND EJW 1022-1 HD FRAME OR EQUAL WITH APPROVAL BY THE VILLAGE WITH TYPE B LID AND CONCEALED PICKHOLE WITH THE WORD "SANITARY" CAST IN THE LID. DIAMETER SHALL BE AS SHOWN ON PLANS. EZ-STICK GASKET OR EQUAL SHALL BE INSTALLED AT ALL JOINTS. EXTERNAL CHIMNEY SEALS SHALL BE INFISHED OR APPROVED EQUAL. EXTERNAL JOINT SEALS TO BE MAC-WRAP OR APPROVED EQUAL. PIPE CONNECTIONS SHALL BE MADE OF FLEXIBLE SYNTHETIC RUBBER BOOTS MEETING ASTM C-923.

CONCRETE ADJUSTING RINGS SHALL NOT EXCEED 8" IN HEIGHT AND 3 IN NUMBER. POLYURETHANE MASTIC SHALL BE INSTALLED BETWEEN EACH JOINT. RUBBER ADJUSTMENT RINGS SHALL BE USED FOR ADJUSTMENT LESS THAN 2".

## 9. TESTING

INFILTRATION-EXFILTRATION SHALL NOT EXCEED 200 GALLONS/INCH DIAMETER/DAY/MILE OF PIPE. TESTING SHALL BE DONE AFTER THE SERVICE LINES HAVE BEEN INSTALLED AND CAPPED.

PVC SDR26 GRAVITY SANITARY SEWER TESTING PROCEDURES FOR WATER TIGHTNESS SHALL INCLUDE LOW PRESSURE AIR TESTING. MINIMUM TESTING PROCEDURE SHALL COMPLY WITH THE STANDARD SPECIFICATIONS FOR SEWER AND WATERMAIN CONSTRUCTION IN ILLINOIS. PVC C-900 GRAVITY SANITARY SEWER TESTING FOR WATER TIGHTNESS SHALL COMPLY WITH FORCE MAIN HYDROSTATIC PRESSURE TESTING REQUIREMENTS.

THE CONTRACTOR SHALL TELEVIEW ALL SANITARY SEWERS CONSTRUCTED, BY CLOSED CIRCUIT T.V., IN ORDER TO DETERMINE ACCEPTANCE. IF THE SEWERS TESTED ARE NOT ACCEPTABLE, THE PROBLEMS FOUND SHALL BE REPAIRED BY THE CONTRACTOR AND THE T.V. TEST REPEATED AT THE CONTRACTOR'S EXPENSE, UNTIL A SATISFACTORY TEST IS OBTAINED. PRIOR TO TELEVIEWING, THE CONTRACTOR SHALL FLUSH AND CLEAN ALL SEWERS WITH WATER. IF THE SEWERS ARE FOUND NOT TO BE CLEAN DURING TELEVIEWING, THE CONTRACTOR WILL BE REQUIRED TO RE-FLUSH AND RE-CLEAN AND THE SEWERS SHALL BE RE-TELEVIEWED AT THE CONTRACTOR'S EXPENSE. ANY SAGS FOUND IN THE SEWER LINE SHALL BE REPAIRED.

VACUUM TESTING OF EACH MANHOLE SHALL BE CARRIED OUT IN ACCORDANCE WITH ASTM C1244 M-20. ALL LIFT HOLES SHALL BE PLUGGED WITH AN APPROVED NON-SHRINK GROUT. NO GROUT WILL BE PLACED IN THE HORIZONTAL JOINTS BEFORE TESTING. ALL PIPES ENTERING THE MANHOLE SHALL BE PLUGGED, TAKING CARE TO SECURELY BRACE THE PLUGS FROM BEING DRAWN INTO THE MANHOLE. THE TEST HEAD SHALL BE PLACED ON THE INSIDE OF THE FRAME AND THE SEAL INFLATED IN ACCORDANCE WITH THE MANUFACTURER'S RECOMMENDATION. IF THE MANHOLE FAILS THE INITIAL TEST, NECESSARY REPAIRS SHALL BE MADE. RETESTING SHALL PROCEED UNTIL A SATISFACTORY TEST IS OBTAINED.

TESTING IS CONSIDERED TO BE INCIDENTAL TO THE COST OF THE SANITARY SEWER

## 10. DEFLECTION TESTING OF FLEXIBLE PIPE

ALL SANITARY SEWERS SHALL BE TESTED FOR DEFLECTION. IF THE DEFLECTION TEST IS TO BE RUN USING A RIGID BALL OR MANDREL, IT SHALL HAVE A DIAMETER EQUAL TO 95% OF THE BASE DIAMETER OF THE PIPE AS ESTABLISHED IN PROPOSED ASTM D-3034. THE TEST SHALL BE PERFORMED WITHOUT MECHANICAL PULLING DEVICES.

THE INDIVIDUAL LINES TO BE TESTED SHALL BE SO TESTED NO SOONER THAN 30 DAYS AFTER THEY HAVE BEEN INSTALLED. WHENEVER POSSIBLE AND PRACTICAL, THE TESTING SHALL INITIATE AT THE DOWNSTREAM LINES AND PROCEED TOWARD THE UPSTREAM LINES. NO PIPE SHALL EXCEED A DEFLECTION OF 5% OF THE BASE INSIDE DIAMETER.

WHERE DEFLECTION IS FOUND TO BE IN EXCESS OF 5% OF THE ORIGINAL PIPE DIAMETER, THE CONTRACTOR SHALL EXCAVATE TO THE POINT OF EXCESS DEFLECTION AND CAREFULLY COMPACT AROUND THE POINT WHERE EXCESS DEFLECTION WAS FOUND. THE LINE SHALL THEN BE RETESTED FOR DEFLECTION. HOWEVER, SHOULD AFTER THE INITIAL TESTING AND THE DEFLECTED PIPE FAIL TO RETURN TO THE ORIGINAL SIZE (INSIDE DIAMETER) THE LINE SHALL BE REPLACED.

## 11. PRESSURE TESTING

ALL SANITARY SEWER FORCE MAIN, FITTINGS AND VALVES SHALL BE SUBJECTED TO A HYDROSTATIC PRESSURE OF 110 PSI AFTER INSTALLATION. EACH SECTION OF SANITARY SEWER FORCE MAIN AND CONNECTIONS TO BE PRESSURE TESTED SHALL BE CAREFULLY FILLED WITH WATER TO EXPEL ALL ENTRAPPED AIR, AND THE TEST PRESSURE SHALL BE APPLIED BY USE OF A PUMP CONNECTED TO A TAP IN THE PIPE. MUST MAINTAIN AN AVERAGE PRESSURE OF GREATER THAN OR EQUAL TO 110 PSI WITH ALLOWABLE RECOVERY. IN THE EVENT OF TEST FAILURE, THE CONTRACTOR SHALL LOCATE AND CORRECT ALL LEAKS, AND THEN REPEAT THE HYDROSTATIC PRESSURE TEST UNTIL SATISFACTORY TO THE ENGINEER.

THE CONTRACTOR SHALL PROVIDE ALL LABOR, MATERIALS, TOOLS, AND EQUIPMENT NECESSARY TO PERFORM THE PRESSURE TEST. THE CONTRACTOR SHALL SATISFACTORILY PERFORM THE PRESSURE TESTS PRIOR TO REQUESTING THE ENGINEER TO WITNESS THE OFFICIAL TESTS. THE CONTRACTOR SHALL NOTIFY THE ENGINEER AT LEAST 48 HOURS PRIOR TO THE TIME THAT THE OFFICIAL TESTS ARE REQUESTED, DEPENDING ON TRAFFIC CONDITIONS, PUBLIC HAZARD, OR OTHER REASONS, THE ENGINEER MAY DIRECT WHEN TESTS OR NEW WORK SHALL BE CONDUCTED.

## 12. TRENCH BACKFILL AND GRANULAR PIPE BEDDING

GRANULAR PIPE BEDDING AND COVER MATERIAL SHALL EXTEND 12" ABOVE THE CROWN OF THE SANITARY SEWER MAIN AND IS INCLUDED IN THE COST OF THE PIPE. THE GRANULAR PIPE BEDDING MATERIAL SHALL CONFORM WITH ASTM SPECIFICATION 2321-89 (CL I A). SAID MATERIAL SHALL BE 100% CRUSHED. CA-7 GRADATION.

## 13. VALVES

SANITARY AIR RELEASE VALVES SHALL BE A.R.I. USA MODEL D-020 OR APPROVED EQUAL. (TWO (2) VALVES FURNISHED, ONE (1) INSTALLED)

SANITARY GATE VALVES SHALL BE MUELLER A-2361 MJ x MJ RWGV OR APPROVED EQUAL. (FORCE MAIN ISOLATION VALVES)

## 14. STEEL CASING PIPE, BORED AND JACKED

STEEL PIPE: NEW STEEL CASING PIPE CONFORMING TO ASTM A139 GRADE A WITH CONTINUOUS FIELD-WELDED BUTT JOINTS IN ACCORDANCE WITH AWWA C206, MINIMUM YIELD STRENGTH OF 35,500 PSI, COATED INSIDE AND OUT WITH AT LEAST ONE SHOP COAT OF PRIMER PAINT, EXTERNAL SURFACE SHALL BE TREATED WITH ONE COAT OF COAL TAR EPOXY OR ASPHALTIC PAINT, AND THE FOLLOWING MINIMUM WALL THICKNESS:

NOMINAL PIPE SIZE 18-INCH, MINIMUM WALL THICKNESS 0.250 INCHES.  
NOMINAL PIPE SIZE 20-INCH, MINIMUM WALL THICKNESS 0.250 INCHES.  
NOMINAL PIPE SIZE 24-INCH, MINIMUM WALL THICKNESS 0.312 INCHES.

CASING SPACERS: THE CARRIER PIPE SHALL BE INSERTED INTO AND SUPPORTED WITHIN THE CASING PIPE BY THE USE OF STAINLESS-STEEL CASING SPACERS. CENTER TO CENTER MEASUREMENT OF CASING SPACERS SHALL BE AS RECOMMENDED BY THE PIPE MANUFACTURER, BUT NO MORE THAN 5-FEET. CASING SPACERS SHALL BE CASCADE WATERWORKS, MODEL CCS OR EQUAL.

SELF-RESTRAINING CASING SPACERS: ALL JOINTS SHALL BE RESTRAINED WITH STAINLESS STEEL SELF-RESTRAINING CASING SPACERS THAT PROVIDE AXIAL THRUST RESTRAINT TO PREVENT JOINT SEPARATION. SELF-RESTRAINING CASING SPACERS SHALL BE CASCADE WATERWORKS, MODEL CCS-JR OR EQUAL.

VOID SPACE FILL: THE VOID SPACE BETWEEN THE CASING PIPE AND CARRIER PIPE SHALL NOT BE FILLED WITH SAND OR OTHER MATERIAL.

END SEALS: ENDS OF THE CASING PIPE SHALL BE SEALED WITH RUBBER END SEALS SECURED IN PLACE WITH STAINLESS STEEL BANDS, CASCADE WATERWORKS, MODEL CCES OR EQUAL.

FOR BID

DRAWN BY: HCM	JOB DATE: 2022	BAR IS ONE INCH ON OFFICIAL DRAWINGS.
APPROVED: SGM	JOB NUMBER: 210915	0
CAD DATE: 1/9/2024 1:33:03 PM		IF NOT ONE INCH, ADJUST SCALE ACCORDINGLY.
CAD FILE: \\hrgreen.com\HRC\Data\2021\210915\CAD\Dwgs\C\210915_CG100_General Notes.dwg		

NO.	DATE	BY	REVISION DESCRIPTION



ILLINOIS DESIGN FIRM # 184.001322  
1391 CORPORATE DRIVE, SUITE 203  
McHENRY, ILLINOIS 60050  
PHONE: 815.385.1778 | TOLL FREE: 800.728.7805  
FAX: 815.385.1781 | HRCgreen.com

EAST SERVICE AREA PHASE 1  
SANITARY SEWER EXTENSION  
VILLAGE OF JOHNSBURG  
JOHNSBURG, ILLINOIS

FOR BID  
GENERAL NOTES AND SPECS

SHEET NO.  
CG002

Xrefs: xg-1-dm01

# GENERAL NOTES & SPECIFICATIONS CONTINUED

## DUPLEX CONCRETE LIFT STATION WITH OUTSIDE VALVE VAULT

### 1. GENERAL

THE WORK IN THIS SECTION SHALL INCLUDE FURNISHING AND PLACING INTO OPERATION TWO (2) SUBMERSIBLE PUMPS, WITH DISCHARGE CONNECTIONS, LIFTING CHAINS WITH HOOKS, ACCESS FRAME WITH COVERS, WIRING BRACKET AND GUIDE BARS AS SPECIFIED HEREIN AND AS INDICATED ON THE DRAWINGS. A NEMA-3R STAINLESS STEEL FREE STANDING WEATHERPROOF TRAFFIC ENCLOSURE WITH A NEMA 1 DUPLEX CONTROL PANEL ENCLOSURE SHALL BE INCLUDED WITH VILLAGE'S STANDARD LEVEL TRANSDUCER, PUMP MANUFACTURER'S STANDARD FLOAT SYSTEM BACK-UP FLOATS, SCADA PANEL, MTS, PROVIDE SPACE FOR FUTURE ATS AND GENERATOR HOUR METER INSIDE TRAFFIC ENCLOSURE AS SHOWN ON THE PLANS.

### 2. WET WELL AND VALVE VAULT

#### A. GENERAL:

A PRECAST CONCRETE WET WELL BASIN AND EXTERNAL VALVE VAULT, MEETING REQUIREMENTS OF ASTM C-478 "STANDARD SPECIFICATION FOR PRECAST REINFORCED CONCRETE MANHOLE SECTIONS", SHALL BE SUPPLIED AND INSTALLED BY THE CONTRACTOR. THE WET WELL AND VALVE VAULT SHALL HAVE AN INSIDE DIMENSION AND AN INSIDE HEIGHT AS SHOWN ON THE PLANS. ALL INTERNAL SURFACES OF THE WET WELL SHALL BE COATED WITH OBIC, MULTI-COMPONENT, STRESS SKIN PANEL LINER SYSTEM, OR APPROVED EQUIVALENT (ADD ALTERNATE BID ITEM). THE EXTERIOR OF THE WET WELL SHALL BE COATED WITH COAL TAR EPOXY, THE EXTERNAL JOINTS OF THE PRECAST CONCRETE SECTIONS SHALL BE MAC-WRAP OR APPROVED EQUAL. HYDROPHILIC WATERSTOP SHALL BE PROVIDED BETWEEN THE WET WELL RISER SECTIONS, SIKA HYDROTITE OR APPROVED EQUAL. THE VALVE VAULT SHALL HAVE A SUMP PIT WITH FIBERGLASS GRATE, AND NON-GFI OUTLET BOX FOR USE WITH THE SUMP PUMP. THE ALUMINUM ACCESS FRAME AND HINGED COVERS SHALL BE CAST INTO EACH BASIN TOP. PUMP MOUNTING PLATES SHALL BE BOLTED TO BASIN BOTTOM. DUCTILE IRON DISCHARGE PIPING FROM PUMP BASES SHALL BE MOUNTED IN THE BASIN AND EXTENDED THROUGH THE WALL FOR CONNECTION TO THE FORCEMAIN.

#### B. PIPING:

PIPING IN THE WET WELL SHALL BE FLANGED DUCTILE IRON PIPE (CLASS 52) AND SHALL TERMINATE OUTSIDE THE BASIN WALL FOR CONNECTION TO THE PIPING IN AN EXTERNAL/INTEGRAL VALVE VAULT. PIPE ENDS BETWEEN STRUCTURES SHALL BE CONNECTED WITH AN APPROVED "FLEX COUPLER" TO ALLOW FOR DIFFERENTIAL SETTLEMENT BETWEEN STRUCTURES. THE VALVE VAULT SHALL INCLUDE (2) NON-CLOG CHECK VALVES-WITH OUTSIDE LEVER AND WEIGHT DESIGN (MUELLER A-2600 SERIES) SWING CHECK VALVES AND (2) HAND WHEEL OPERATED (MUELLER A2361) RESILIENT WEDGE GATE VALVES. A THIRD GATE VALVE SHALL BE FOR USE WITH A BY-PASS RISER AND QUICK DISCONNECT HOSE COUPLING FOR PORTABLE PUMP CONNECTION, AS SHOWN ON THE PLANS. THE BYPASS RISER SHALL HAVE (1) DIXON COUPLING CO. #600-F-AL MALE FITTING WITH DUST CAP ATTACHED OR APPROVED EQUAL. INLET OR INLETS INTO BASIN SHALL BE FURNISHED WITH LINK-SEAL MODULAR SEALS OR APPROVED EQUAL FOR INLET PIPE(S), AS SHOWN ON THE PLANS. THE PUMP GUIDE RAILS SHALL BE 2" STAINLESS STEEL PIPE. LIFT STATION DISCHARGE PIPE SHALL BE DUCTILE IRON PIPE FOR CONNECTION TO THE FORCEMAIN. A 6" STAINLESS STEEL VENT PIPE WITH STAINLESS STEEL INSECT SCREEN SHALL BE INSTALLED ON BOTH BASINS AS SHOWN ON THE PLANS.

ALL INTERIOR WET WELL AND VALVE VAULT PIPING SHALL BE PAINTED. PIPE COATING:

SURFACE PREPARATION: ABRASIVE BLAST CLEAN IN ACCORDANCE WITH NAFF 500-03-04 FOR PIPE AND NAFF 500-03-05 FOR FITTINGS

PRIME COAT: SHOP APPLIED AND FIELD PATCHED, 1 COAT/4.0 TO 6.0 DFT TNEMEC N140 POTA-POX PLUS

FIRST COAT: 1 COAT/4.0 TO 6.0 DFT TNEMEC "N69 HI-BUILD EPOXOLINE II"

TOP COAT: 1 COAT/4.0 TO 6.0 DFT TNEMEC "N69 HI-BUILD EPOXOLINE II"

COLOR: BATTLESHIP GREY - N69-GR13

TOTAL FIRST AND TOP COATING SYSTEM 8.0-11.0 MILS DRY FILM THICKNESS.

#### C. PUMP GUIDE RAIL SYSTEM:

THE PUMP GUIDE RAIL SYSTEM FOR EACH PUMP SHALL INCLUDE A DISCHARGE BASE ELBOW WITH LOWER GUIDE RAIL BRACKET, UPPER GUIDE BRACKET, STAINLESS STEEL LIFTING CHAIN, AND NO LESS THAN 2 STAINLESS STEEL GUIDE RAILS, SYSTEMS UTILIZING A SINGLE GUIDE RAIL OR GUIDE CABLES SHALL NOT BE ACCEPTABLE. THE BASE ELBOW, SIZED AS SHOWN ON THE PLANS AND AS SUGGESTED BY THE MANUFACTURER, SHALL BE DESIGNED TO ACCOMMODATE THE MAXIMUM FLOW CONDITIONS. THE DISCHARGE BASE ELBOW, MOUNTED DIRECTLY ON THE SUMP FLOOR, SHALL HAVE A STANDARD 125 LB FLANGE, WITH MACHINED FACE. THE DESIGN SHALL BE SUCH THAT THE PUMP TO DISCHARGE CONNECTION IS MADE WITHOUT THE NEED FOR ANY NUTS, BOLTS, OR GASKETS. THE BASE ELBOW SHALL ALSO ANCHOR TWO (2) 2" 316 STAINLESS STEEL GUIDE RAILS FOR EACH PUMP. SEALING THIS PUMP DISCHARGE CONNECTION SHALL BE ACCOMPLISHED BY SIMPLE LINEAR DOWNWARD MOTION OF THE PUMP CULMINATING WITH THE ENTIRE WEIGHT OF THE PUMPING UNIT SUPPORTED ENTIRELY BY THE BASE ELBOW. NO PORTION OF THE PUMP SHALL BEAR DIRECTLY ON THE SUMP FLOOR. THE SLIDE BRACKET/INTERFACE FLANGE BETWEEN THE PUMP AND DISCHARGE ELBOW SHALL BE REMOVABLE AND BOLT DIRECTLY TO THE PUMP VOLUTE FLANGE USING A 125# ANSI BOLT PATTERN. THE STAINLESS STEEL UPPER GUIDE BRACKET SHALL ALIGN AND SUPPORT THE TWO GUIDE RAILS AT THE TOP OF THE WET WELL. IT SHALL BOLT DIRECTLY TO THE HATCH FRAME AND INCORPORATE AN EXPANDABLE RUBBER GROMMET. EACH PUMP SHALL BE PROVIDED WITH A STAINLESS STEEL LIFTING CHAIN, AND BE OF SUFFICIENT LENGTH TO EXTEND FROM THE PUMP TO THE TOP OF THE WET WELL, PLUS (+) THREE (3) FEET. THE ACCESS FRAME SHALL PROVIDE 6 HOOKS/STAINLESS STEEL BRACKETS TO ATTACH THE CHAIN WHEN NOT IN USE. THE STAINLESS STEEL LIFTING CHAIN SHALL BE SIZED ACCORDING TO THE PUMP WEIGHT. THE STAINLESS STEEL LIFTING CHAIN SHALL BE CONNECTED TO THE TOP OF EACH PUMP WITH STAINLESS STEEL SCREW PIN ANCHOR SHACKLE OR OTHER SUITABLE MECHANISM TO FACILITATE EASY DISCONNECT OF THE PUMP FROM THE CHAIN ONCE PUMP IS REMOVED. PLATES, FITTINGS, SEALING FACE OF DISCHARGE ELBOW AND OTHER MATERIALS SHALL BE COATED WITH PROTECTIVE LAYERS OF EPOXY PAINT TO

PREVENT CORROSION. ALL ANCHOR BOLTS AND CONNECTING BOLTS SHALL BE MADE OF 316 STAINLESS STEEL SUITABLE FOR USE IN THIS CORROSIVE ENVIRONMENT.

#### D. ACCESS FRAME AND COVER:

A DUPLEX DOOR ACCESS FRAME ASSEMBLY, SHALL BE INSTALLED AND SIZED IN ACCORDANCE WITH THE PUMP MANUFACTURERS REQUIREMENTS. ACCESS FRAME AND COVERS SHALL BE FABRICATED OF ALUMINUM AND CAST INTO THE BASIN FLAT TOP. FRAME SHALL SUPPORT GUIDE RAILS AND ELECTRICAL WIRING BRACKET. A SEPARATE HINGED COVER SHALL BE PROVIDED FOR EACH PUMP. COVER SHALL BE PROVIDED WITH LIFTING HANDLE AND SAFETY LATCH TO HOLD COVER IN THE OPEN POSITION. A SINGLE LOCK MECHANISM SHALL BE FURNISHED FOR EACH MULTIPLE HATCH ENTRY COVER. A PADLOCK HASP SHALL BE PROVIDED BY MANUFACTURER. THE OUTSIDE OF THE FRAME SHALL HAVE A PROTECTIVE COATING APPLIED WHERE THE ALUMINUM FRAME COMES IN CONTACT WITH THE CONCRETE. A SIMILAR DOOR ACCESS FRAME ASSEMBLY SHALL BE INSTALLED AS DETERMINED BY PUMP MANUFACTURER, AND THE VALVE VAULT COVER SIZED AS SHOWN ON THE PLANS. EACH ACCESS COVER SHALL INCORPORATE AN ALUMINUM SAFETY GRATE. EACH GRATE SHALL HAVE AN OPENING ARM, WITH A RED VINYL GRIP HANDLE, WHICH WILL ALLOW OPENING OF THE GRATE, WHILE PROVIDING THE GRATE AS A BARRIER BETWEEN THE OPERATOR AND THE PIT. THE OPENING ARM SHALL ALSO BE EQUIPPED WITH A CONTROLLED CONFINED SPACE ENTRY LOCKING DEVICE (LOCK PROVIDED BY OTHERS). THIS LOCKING DEVICE WILL PREVENT UNAUTHORIZED ENTRY TO THE CONFINED SPACE. THE GRATING SYSTEM WILL ALLOW ANYONE TO MAKE VISUAL INSPECTION AND PROBE/FLOAT ADJUSTMENTS WITHOUT ENTERING THE CONFINED SPACE. DESIGN OF THE FALL RESTRAINT SYSTEM MUST ASSURE FALL THROUGH PROTECTION IS IN PLACE AFTER THE DOOR HAS BEEN CLOSED, THEREBY PROTECTING THE NEXT OPERATOR. THE GRATE SHALL BE DESIGNED TO WITHSTAND A MINIMUM PEDESTRIAN LOAD OF 300 LBS. PER SQUARE FOOT. THE GRATE SHALL OPERATE INDEPENDENT OF THE COVER'S REINFORCING SO THAT THE COVER WILL CONTINUE TO MEET SPECIFIED LOAD AND DEFLECTION REQUIREMENTS, EVEN IF THE GRATE'S LEAFS ARE DAMAGED OR REMOVED. GRATE SHALL BE PAINTED WITH O.S.H.A TYPE SAFETY ORANGE PAINT. MANUFACTURER SHALL PROVIDE A WRITTEN GUARANTEE AGAINST DEFECTS IN MATERIALS OR WORKMANSHIP FOR A PERIOD OF TEN (10) YEARS.

#### E. WIRING BRACKET:

A 316 STAINLESS STEEL WIRING BRACKET SHALL PROVIDE CORD GRIP HOLDERS FOR THE PUMP SENSOR CORDS, CONTROL CORDS AND THE BACK-UP FLOAT CORDS. ALL CORDS SHALL EXTEND FROM BRACKET THROUGH CONDUIT TO CONTROL BOX. NO SPLICES SHALL BE MADE IN THE WIRING. CONTINUOUS CORDS MUST BE USED FROM CONTROL PANEL TO PUMPS AND CONTROLS. WIRING BRACKET SHALL BE FASTENED TO ACCESS FRAME OR CONCRETE FLAT TOP STRUCTURE. THE INSTALLING CONTRACTOR SHALL BE RESPONSIBLE FOR STRAIN RELIEF CORD GRIPS FOR THE PUMP POWER CORDS AND THE SUBMERSIBLE LEVEL TRANSDUCER.

#### 3. SUBMERSIBLE PUMPS

##### A. GENERAL:

EACH PUMP SHALL BE MANUFACTURED BY FLYGT, PENTAIR/HYDROMATIC OR ENGINEER/VILLAGE PRE-APPROVED EQUAL, AND SEALED SUBMERSIBLE TYPE SIZED IN ACCORDANCE WITH THE "OPERATING CONDITIONS AND PUMP UNIT SCHEDULE" BELOW. TO BE CONSIDERED FOR BIDDING, A COMPLETE SUBMITTAL OF THE PUMP, CONTROL SYSTEM, SERVICE FACILITIES AND 5 MUNICIPAL REPAIR SERVICE REFERENCES SHALL BE SUBMITTED TO THE ENGINEER A MINIMUM OF 10 DAYS PRIOR TO BID DATE. A FIVE (5) YEAR WARRANTY ON THE PUMPS IS TO BE PROVIDED. THE STATION SHALL BE EQUIPPED WITH 2 SUBMERSIBLE, CLOSE-COUPLED WASTEWATER PUMPS. EACH PUMP SHALL BE EQUIPPED WITH A 5 HP SUBMERSIBLE ELECTRIC MOTOR, CAPABLE TO OPERATE ON A 460 VOLT, 3 PHASES, 60 HERTZ VOLTAGE SUPPLY. THE HYDRAULIC OF THE PUMP SHALL BE EQUIPPED WITH A SEMI OPEN MULTI VANE IMPELLER DESIGNED TO TRANSPORT WASTEWATER. THE IMPELLER BLADES SHALL BE SELF-CLEANING UPON EACH ROTATION AS THEY PASS ACROSS A SHARP RELIEF GROOVE IN THE INSERT RING AND SHALL KEEP THE IMPELLER BLADES CLEAR OF DEBRIS. THE CLEARANCE BETWEEN THE INSERT RING AND THE IMPELLER LEADING EDGES SHALL BE ADJUSTABLE. THE IMPELLER SHALL BE WEAR RESISTANT AND MADE OF HIGH CHROMIUM CAST IRON WITH AT LEAST 24% CHROME AGAINST SAND AND GRIT WHICH IS EXPECTED TO ENTER THE PUMP STATION WITH THE SEWAGE WATER. IMPELLERS THAT HAVE SURFACE HARDENING (BY THERMAL, COATING, ETC.) WILL NOT BE ALLOWED. THE PUMP SHALL BE CAPABLE TO OPERATE WITHOUT ANY LIMITATION BETWEEN 50% AND 125% OF THE BEST EFFICIENCY POINT (B.E.P) OF THE PERFORMANCE CURVE. THE MOTOR SPEED SHALL BE MAX.: 1760 RPM. A PERFORMANCE CHART SHALL BE PROVIDED UPON REQUEST SHOWING CURVES FOR TORQUE, CURRENT, POWER FACTOR, INPUT/OUTPUT HP AND EFFICIENCY. THIS CHART SHALL ALSO INCLUDE DATA ON STARTING AND NO-LOAD CHARACTERISTICS. THE IMPELLER SHALL BE MOUNTED ON THE MOTOR SHAFT. THE IMPELLER MUST BE ABLE TO PASS A 3" NON-COMPRESSIBLE SOLID. COUPLINGS SHALL NOT BE ACCEPTED. THE PUMP MOTOR SHALL BE INDUCTION TYPE WITH A SQUIRREL CAGE ROTOR, SHELL TYPE DESIGN, HOUSED IN AN AIR FILLED, WATERTIGHT CHAMBER. IT SHALL BE PERMANENTLY SUBMERSIBLE ACCORDING STANDARD IEC 60034 AND PROTECTION CLASS IP 68. THE MOTOR SHALL BE PROVIDED WITH AN INTEGRAL MOTOR COOLING SYSTEM. A STAINLESS STEEL COOLING JACKET SHALL ENCIROLE THE STATOR HOUSING, PROVIDING FOR DISSIPATION OF MOTOR HEAT REGARDLESS OF THE TYPE OF PUMP INSTALLATION. AN IMPELLER, INTEGRAL TO THE COOLING SYSTEM AND DRIVEN BY THE PUMP SHAFT, SHALL PROVIDE THE NECESSARY CIRCULATION OF THE COOLING LIQUID THROUGH THE JACKET. THE COOLING LIQUID SHALL PASS ABOUT THE STATOR HOUSING IN THE CLOSED LOOP SYSTEM IN TURBULENT FLOW PROVIDING FOR SUPERIOR HEAT TRANSFER. THE COOLING SYSTEM SHALL HAVE ONE FILL PORT AND ONE DRAIN PORT INTEGRAL TO THE COOLING JACKET. THE PUMP SHALL BE CAPABLE OF OPERATING IN A CONTINUOUS CONDITION IN A LIQUID WITH A TEMPERATURE UP TO 104°F EVEN WHEN THE MOTOR IS NOT SUBMERGED. THE MOTOR SHALL BE CAPABLE OF NO LESS THAN 30 EVENLY SPACED STARTS PER HOUR AND BE ABLE TO OPERATE THROUGHOUT THE ENTIRE PUMP PERFORMANCE CURVE FROM SHUT-OFF THROUGH RUN-OUT. THE STATOR WINDINGS SHALL BE INSULATED WITH MOISTURE RESISTANT CLASS H INSULATION RATED FOR 356°F. SEALING OF THE PUMPING UNIT TO THE DISCHARGE CONNECTION SHALL BE ACCOMPLISHED BY A MACHINED METAL TO METAL WATERTIGHT CONTACT. SEALING OF THE DISCHARGE INTERFACE WITH A DIAPHRAGM, O-RING OR PROFILE GASKET WILL NOT BE ACCEPTABLE. IT SHALL BE POSSIBLE TO LIFT AND LOWER THE PUMPS ON PARALLEL GUIDE BARS AND CONNECT THEM TO WET WELL MOUNTED DISCHARGE CONNECTION. THERE SHALL BE NO NEED FOR PERSONAL TO ENTER THE WET WELL WHEN REMOVING OR REINSTALLING THE PUMPS. THE PUMP HOUSING SHALL BE PREPARED FOR THE ASSEMBLING OF A SUMP MIXING VALVE. THE JUNCTION CHAMBER CONTAINING THE TERMINAL BOARD SHALL BE HERMETICALLY SEALED FROM THE

MOTOR BY AN ELASTOMERIC COMPRESSION SEAL. CONNECTION BETWEEN THE CABLE CONDUCTORS AND STATOR LEADS SHALL BE MADE WITH THREADED COMPRESSION TYPE BINDING POSTS PERMANENTLY AFFIXED TO A TERMINAL BOARD. THE MOTOR AND THE PUMP SHALL BE PRODUCED BY THE SAME MANUFACTURER. THE MOTOR SHALL BE PROTECTED BY 3 THERMAL SWITCHES EMBEDDED IN THE STATOR SET TO OPEN AT 284°F (140°C) AND ONE LEAKAGE SENSOR. FLOATING TYPE LOCATED IN A LEAKAGE CHAMBER BELOW THE MAIN BEARING. THE SENSOR AND THE SWITCHES SHALL BE CONNECTED TO THE CONTROL PANEL WHICH SHALL STOP THE MOTOR AND SEND AN ALARM WHEN THE SENSORS ARE ACTIVATED. THE PUMP SHALL BE EXPLOSION APPROVED ACCORDING FM CLASS 1, DIV 1 "C" & "D". THE CABLE ENTRY SHALL CONSIST OF DUAL CYLINDRICAL ELASTOMER SLEEVES, FLANKED BY WASHERS, ALL HAVING A CLOSE TOLERANCE FIT AGAINST THE CABLE AND THE CABLE ENTRY, EPOXIES, SILICONES, OR OTHER SECONDARY SEALING SYSTEMS SHALL NOT BE CONSIDERED ACCEPTABLE. THE PUMP SHAFT SHALL ROTATE ON TWO BEARINGS. MOTOR BEARINGS SHALL BE PERMANENTLY GREASE LUBRICATED AND HAVE A NOMINAL L10 LIFETIME OF 50,000 HOURS. THE UPPER BEARING SHALL BE A SINGLE DEEP GROOVE BALL BEARING. THE LOWER BEARING SHALL BE A TWO ROW ANGULAR CONTACT BEARING TO COMPENSATE FOR AXIAL THRUST AND RADIAL FORCES. SINGLE ROW LOWER BEARINGS ARE NOT ACCEPTABLE. EACH PUMP SHALL BE PROVIDED WITH A POSITIVELY DRIVEN DUAL, TANDEM MECHANICAL SHAFT SEAL SYSTEM CONSISTING OF TWO SEAL SETS, EACH HAVING AN INDEPENDENT SPRING. THE LOWER PRIMARY SEAL, LOCATED BETWEEN THE PUMP AND SEAL CHAMBER, SHALL CONTAIN ONE STATIONARY AND ONE POSITIVELY DRIVEN ROTATING CORROSION AND ABRASION RESISTANT TUNGSTEN-CARBIDE RING. THE UPPER SECONDARY SEAL, LOCATED BETWEEN THE SEAL CHAMBER AND THE SEAL INSPECTION CHAMBER SHALL BE A LEAKAGE-FREE SEAL. THE UPPER SEAL SHALL CONTAIN ONE STATIONARY AND ONE POSITIVELY DRIVEN ROTATING CORROSION AND ABRASION RESISTANT TUNGSTEN-CARBIDE SEAL RING. THE ROTATING SEAL RING SHALL HAVE SMALL BACK-SWEEP GROOVES LASER INSCRIBED UPON ITS FACE TO ACT AS A PUMP AS IT ROTATES, RETURNING ANY FLUID THAT SHOULD ENTER THE DRY MOTOR CHAMBER BACK INTO THE LUBRICANT CHAMBER. ALL SEAL RINGS SHALL BE INDIVIDUAL SOLID SINTERED RINGS. EACH SEAL INTERFACE SHALL BE HELD IN PLACE BY ITS OWN SPRING SYSTEM. THE SEALS SHALL NOT DEPEND UPON DIRECTION OF ROTATION FOR SEALING. MOUNTING OF THE LOWER SEAL ON THE IMPELLER HUB IS NOT ACCEPTABLE. SHAFT SEALS WITHOUT POSITIVELY DRIVEN ROTATING MEMBERS OR CONVENTIONAL DOUBLE MECHANICAL SEALS CONTAINING EITHER A COMMON SINGLE OR DOUBLE SPRING ACTING BETWEEN THE UPPER AND LOWER SEAL FACES ARE NOT ACCEPTABLE. THE SEAL SPRINGS SHALL BE ISOLATED FROM THE PUMPED MEDIA TO PREVENT MATERIALS FROM PACKING AROUND THEM, LIMITING THEIR PERFORMANCE. ANY LEAKAGE PASSING THE SEALING SHALL NOT PASS THE BEARINGS. BEFORE IT REACHES THE BEARINGS THE LIQUID SHALL CREATE AN ALARM VIA THE FLOATING LEAKAGE SENSOR. EACH PUMP SHALL BE PROVIDED WITH A LUBRICANT CHAMBER FOR THE SHAFT SEALING SYSTEM. THE LUBRICANT CHAMBER SHALL BE DESIGNED TO PREVENT OVERFILLING AND TO PROVIDE LUBRICANT EXPANSION CAPACITY. THE DRAIN AND INSPECTION PLUG, WITH POSITIVE ANTI-LEAK SEAL SHALL BE EASILY ACCESSIBLE FROM THE OUTSIDE. THE SEAL SYSTEM SHALL NOT RELY UPON THE PUMPED MEDIA FOR LUBRICATION. SEAL LUBRICANT SHALL BE NON-HAZARDOUS. WHERE A SEAL CAVITY IS PRESENT IN THE SEAL CHAMBER, THE AREA ABOUT THE EXTERIOR OF THE LOWER MECHANICAL SEAL IN THE CAST IRON HOUSING SHALL HAVE CAST IN AN INTEGRAL CONCENTRIC SPIRAL GROOVE. THIS GROOVE SHALL PROTECT THE SEALS BY CAUSING ABRASIVE PARTICULATE ENTERING THE SEAL CAVITY TO BE FORCED OUT AWAY FROM THE SEAL DUE TO CENTRIFUGAL ACTION. ALL CASTINGS MUST BE BLASTED BEFORE COATING. ALL WET SURFACES ARE TO BE COATED WITH TWO-PACK OXYGEN ESTER DIASOLID 50. THE TOTAL LAYER THICKNESS SHOULD BE AT LEAST 120 MICRONS. ZINC DUST PRIMER SHALL NOT BE USED. THE MOTOR SHALL BE EQUIPPED WITH MINIMUM 50 FEET OF SCREENED CABLE SUITABLE FOR SUBMERSIBLE PUMP APPLICATIONS. THE POWER CABLE SHALL BE SIZED ACCORDING TO NEC AND IECA. THE OUTER JACKET OF THE CABLE SHALL BE OIL RESISTANT CHLORINATED POLYETHYLENE RUBBER. THE CABLE SHALL BE CAPABLE OF CONTINUOUS SUBMERGENCE UNDERWATER WITHOUT LOSS OF WATERTIGHT INTEGRITY TO A DEPTH OF 65 FEET.

##### B. POWER CORD:

THE POWER CABLE SHALL INCLUDE GROUND AND BE SIZED IN ACCORDANCE WITH NEC AND IECA STANDARDS AND SHALL BE OF SUFFICIENT LENGTH TO REACH THE HAZARDOUS ENTRY WITHOUT THE NEED OF ANY SPLICES. THE OUTER JACKET OF THE CABLE SHALL BE OIL RESISTANT CHLOROPRENE RUBBER. THE CABLE ENTRY SYSTEM SHALL PRECLUDE SPECIFIC TORQUE REQUIREMENTS AND CONSIST OF A SINGLE CYLINDRICAL ELASTOMERIC GROMMET TO INSURE A COMPLETELY WATERTIGHT AND SUBMERSIBLE SEAL. THE CYLINDRICAL ELASTOMERIC GROMMET SHALL BE FLANKED BY WASHERS, ALL HAVING A CLOSE TOLERANCE FIT AGAINST THE CABLE OUTSIDE DIAMETER AND ENTRY INSIDE DIAMETER, AND SHALL BE COMPRESSED BY THE BODY CONTAINING A STRAIN RELIEF FUNCTION SEPARATE FROM THE FUNCTION OF SEALING THE CABLE.

##### C. OPERATING CONDITIONS AND PUMPING UNIT SCHEDULE:

THE SUBMERSIBLE PUMPS SHALL BE SIZED/RATED FOR 325 GPM @ 28.72' TDH. TWO FLYGT MODEL NP3102, PENTAIR/HYDROMATIC MODEL S4NX500 OR ENGINEER/VILLAGE PRE-APPROVED EQUIVALENT SHALL BE SUPPLIED. MOTOR NAME PLATE HP SHALL BE NO GREATER THAN 5 HP. MOTOR RPM SHALL NOT EXCEED 1760 RPM. THE MOTOR SHALL BE NON-OVER LOADING AT ANY USABLE PORTION OF THE PUMP CURVE. PUMP SHUT OFF SHALL BE NO LESS THAN 45'.

THE POWER SUPPLIED TO THIS LIFT STATION SHALL BE 277/480 VOLT, 3 PHASE, 4 WIRE SERVICE RATED AT 100 AMPS. THE SERVICE ENTRANCE EQUIPMENT SHALL BE SIZED FOR THE PUMPING EQUIPMENT AND SHALL BE CONFIRMED BY THE OWNER PRIOR TO ORDERING EQUIPMENT. DESIGN ENGINEER TO CONFIRM POWER REQUIREMENTS BASED ON ACTUAL PUMP DESIGN AND COORDINATION WITH COMED.

##### D. EQUIPMENT RESPONSIBILITY:

ALL CONTROLS, PUMPS, ACCESS COVERS AND MOTORS SHALL BE FURNISHED BY ONE EQUIPMENT SUPPLIER. THE EQUIPMENT SUPPLIER SHALL HAVE RESPONSIBILITY FOR THE COMPLETE AND PROPER OPERATION OF THE NEW PUMPING EQUIPMENT, CONTROL EQUIPMENT, AND PROGRAM AS SPECIFIED AND FURNISHED. THE SYSTEM SUPPLIER SHALL FURNISH 24 HOUR SERVICE FOR THE COMPLETE SYSTEM. SHALL STOCK REPAIR PARTS FOR THE INSTALLATION AND SHALL HAVE AN IN HOUSE PUMP SERVICE FACILITY TO SERVICE THE PUMPING EQUIPMENT. START-UP SERVICES SHALL BE INCLUDED, AND SHALL INCLUDE OPERATING INSTRUCTION TO THE OPERATORS.

##### E. SHOP DRAWINGS (ELECTRONIC SUBMITTALS):

THE CONTRACTOR SHALL SUBMIT ELECTRONIC COPIES OF ALL SUBMITTALS TO THE ENGINEER FOR APPROVAL. A COPY OF THE REVIEWED SUBMITTAL WILL BE RETURNED TO THE CONTRACTOR WITH THE APPROPRIATE ACTION NOTED. EACH SET OF SHOP DRAWINGS SHALL INCLUDE, BUT NOT NECESSARILY BE LIMITED TO:

STANDARD SUBMITTAL DATA FOR APPROVAL MUST CONSIST OF:

- PUMP PERFORMANCE CURVES.
- PUMP OUTLINE DRAWING.
- EQUIPMENT DRAWINGS.
- CONTROL DETAILS AND ELECTRICAL SCHEMATIC DIAGRAMS.
- STATION DRAWING FOR ACCESSORIES.
- ELECTRICAL MOTOR DATA.
- TYPICAL INSTALLATION GUIDES.
- TECHNICAL MANUALS AND PARTS LIST.
- PRINTED WARRANTY.
- MANAGEMENT SYSTEM CERTIFICATE ISO 9001.
- MANUFACTURER'S EQUIPMENT STORAGE RECOMMENDATIONS.
- MANUFACTURER'S STANDARD RECOMMENDED START-UP REPORT FORM.
- ALL OTHER INFORMATION NECESSARY TO ENABLE THE ENGINEER TO DETERMINE WHETHER THE PROPOSED EQUIPMENT MEETS THE REQUIREMENTS.

LACK OF THE ABOVE REQUESTED SUBMITTAL DATA IS CAUSE FOR REJECTION.

##### B. INSTALLATION, OPERATING AND MAINTENANCE INSTRUCTIONS:

THREE (3) COPIES OF A MANUAL, CONTAINING INSTALLATION INSTRUCTIONS, OPERATING INSTRUCTIONS, WIRING DIAGRAMS, PARTS LIST, AND WHERE APPLICABLE, TEST DATA AND CURVES SHALL BE PROVIDED. THE CONTRACTOR SHALL PROVIDE THE SERVICES OF A FACTORY-TRAINED REPRESENTATIVE FOR A MAXIMUM PERIOD OF ONE (1) DAY TO START UP THE STATION AND TO INSTRUCT THE OWNER'S OPERATING PERSONNEL IN THE OPERATION AND MAINTENANCE OF THE EQUIPMENT PROVIDED.

##### C. WARRANTY

FOR THE PERIOD DEFINED BELOW, THE PUMP MANUFACTURER SHALL OFFER A WARRANTY TO THE VILLAGE AGAINST DEFECTS IN WORKMANSHIP AND MATERIAL COVERING PARTS AND LABOR. WARRANTIES AND GUARANTEES BY THE SUPPLIERS OF VARIOUS COMPONENTS IN LIEU OF A SINGLE SOURCE RESPONSIBILITY BY THE CONTRACTOR SHALL NOT BE ACCEPTED. THE CONTRACTOR SHALL BE SOLELY RESPONSIBLE FOR THE WARRANTY. IN THE EVENT A COMPONENT FAILS TO PERFORM AS SPECIFIED OR IS PROVEN DEFECTIVE IN SERVICE DURING THE WARRANTY PERIOD, EXCLUDING ITEMS OF SUPPLY NORMALLY EXPENDED DURING OPERATION, THE MANUFACTURER SHALL PROVIDE A REPLACEMENT PART WITHOUT COST TO THE OWNER. THIS WARRANTY SHALL BE VALID ONLY IF THE PRODUCT IS INSTALLED, SERVICED, AND OPERATED UNDER NORMAL CONDITIONS, IN ACCORDANCE WITH THE MANUFACTURER INSTRUCTIONS.

THE PUMPS SHALL BE PROVIDED WITH PRORATED 60 MONTHS (5 YEARS) WARRANTY AGAINST DEFECTS IN MATERIALS AND OR WORKMANSHIP. UNLESS OTHERWISE SPECIFIED, ALL OTHER EQUIPMENT SHALL BE WARRANTED FOR 12 MONTHS (1 YEAR). THE WARRANTY SHALL BE IN PRINTED FORM AND PREVIOUSLY PUBLISHED AS THE MANUFACTURER'S STANDARD WARRANTY FOR ALL SIMILAR UNITS MANUFACTURED, LATEST REVISION. UPON WARRANTY OCCURRENCE, THE MANUFACTURER'S AUTHORIZED SERVICE CENTER SHALL REMOVE THE PUMP, REPAIR, REINSTALL AND PROVIDE START UP ON THE REPAIRED PUMP.

WARRANTY SHALL BEGIN ON THE DATE OF START-UP. THE PUMP MANUFACTURER SHALL PAY THE FOLLOWING MINIMUM SHARE OF THE COST OF REPLACEMENT PARTS AND LABOR PROVIDED THE PUMP, WITH CABLE ATTACHED, IS RETURNED PREPAID TO AN AUTHORIZED SERVICE FACILITY FOR REPAIRS.

TIME AFTER START-UP:	0-18	19-39	40-60
MONTHS:			
WARRANTY:	100%	50%	25%

A DETAILED FAILURE ANALYSIS SHALL BE SUBMITTED TO THE OWNER FOR THEIR RECORDS SUMMARIZING CORRECTIVE ACTION TAKEN. THE MANUFACTURER SHALL GUARANTEE CLOG-FREE OPERATION FOR A PERIOD OF 12 MONTHS FROM THE DATE OF START-UP OF THE PUMPS BY THE LOCAL AUTHORIZED FACTORY REPRESENTATIVE. A CERTIFICATE SHALL BE PROVIDED TO THE OWNER ON THE DAY OF START UP WITH THE LOCAL CONTACT INFORMATION AND EFFECTIVE DATE. IF THE IMPELLER CLOGS WITH TYPICAL SOLIDS OR MODERN TRASH DEBRIS NORMALLY FOUND IN DOMESTIC WASTEWATER DURING THIS PERIOD, AN AUTHORIZED REPRESENTATIVE SHALL TRAVEL TO THE JOBSITE, REMOVE THE PUMP, CLEAR THE OBSTRUCTION AND REINSTALL THE PUMP AT NO COST FOR THE OWNER. A WRITTEN REPORT SHALL BE PROVIDED TO THE OWNER DETAILING THE SERVICE CALL WITH PICTURES FOR VERIFICATION PURPOSES.

##### A. EQUIPMENT MANUFACTURER:

IN ORDER TO ESTABLISH A STANDARD OF QUALITY AND TO INSURE A UNIFORM BASIS OF BIDDING, PUMP STATION EQUIPMENT SHALL BE FLYGT, PENTAIR/HYDROMATIC OR ENGINEER/VILLAGE EQUIVALENT. THE CONTRACTOR SHALL PREPARE HIS BID ON THE BASIS OF THE SPECIFIC EQUIPMENT AND MATERIALS SPECIFIED FOR PURPOSE OF DETERMINING THE LOW BID.

##### B. SUMP PUMP:

THE SUMP PUMP SHALL PUMP ANY LEAKAGE OR WASH DOWN WATER FROM THE VALVE VAULT. THE SUMP PUMP SHALL BE A EBARA EPD-3 SUBMERSIBLE SUMP PUMP OR APPROVED EQUAL. THE MOTOR SHALL BE A CONTINUOUS DUTY, MINIMUM 1/3 HP WITH BUILT IN AUTOMATIC RESET OVERLOAD PROTECTION. AN ADJUSTABLE FLOAT SHALL BE PROVIDED TO START AND STOP THE PUMP AT PREDETERMINED SUMP LEVELS. ANY APPLICABLE CONTROL CIRCUITRY AND STARTERS SHALL BE HOUSED IN THE CONTROL PANEL.

FOR BID

DRAWN BY: HCM	JOB DATE: 2022	BAR IS ONE INCH ON OFFICIAL DRAWINGS.
APPROVED: SGM	JOB NUMBER: 210915	0" = 1"
CAD DATE: 1/9/2024 1:33:03 PM		IF NOT ONE INCH, ADJUST SCALE ACCORDINGLY.
CAD FILE: \\hrgreen.com\HRG\Data\2021\210915\CAD\Dwgs\C\210915_CG100_General Notes.dwg		

NO.	DATE	BY	REVISION DESCRIPTION

ILLINOIS DESIGN FIRM # 184.001322  
 1391 CORPORATE DRIVE, SUITE 203  
 McHENRY, ILLINOIS 60050  
 PHONE: 815.385.1778 | TOLL FREE: 800.728.7805  
 FAX: 815.385.1781 | HRGreen.com



EAST SERVICE AREA PHASE 1  
 SANITARY SEWER EXTENSION  
 VILLAGE OF JOHNSBURG  
 JOHNSBURG, ILLINOIS

FOR BID  
**GENERAL NOTES AND SPECS**

SHEET NO.  
**CG003**

GENERAL NOTES & SPECIFICATIONS CONTINUED

DUPLEX CONCRETE LIFT STATION WITH OUTSIDE VALVE VAULT

4. CONTROL EQUIPMENT

A. GENERAL:

THE PROCESSOR BASED CONTROL PANEL SHALL HAVE A NEMA-1 ENCLOSURE, MOUNTED IN THE NEMA-3R STAINLESS STEEL TRAFFIC ENCLOSURE AND SHALL HAVE OPERATORS THROUGH THE DOOR WITH SEPARATE REMOVABLE INSIDE SUB PANEL. A LOCK HASP SHALL BE PROVIDED ON OUTSIDE DOOR. SUPPORTS TO HOLD THE DOORS OPEN ARE TO BE PROVIDED. A CLIP BOARD HOLDER IS TO BE MOUNTED TO THE INSIDE OF ONE OF THE OUTSIDE DOORS. A SEPARATE POWER DISTRIBUTION PANEL SHALL INCLUDE CIRCUIT BREAKER FOR THE TWO PUMPS, AS WELL AS A BREAKER TO FEED THE LIGHTING PANEL AND TRANSFORMER. THE CONTROLLER SHALL HANDLE THE ALTERNATING OF PUMPS, ADJUSTMENT OF LEVELS, AND BE CAPABLE OF RUNNING TWO PUMPS WITH MINOR PROGRAMMING CHANGES. STARTERS SHALL HAVE AUXILIARY CONTACTS TO OPERATE THE PUMPS ON OVERRIDE CONDITIONS. AN INTERLOCK RELAY SHALL BE PROVIDED TO AUTOMATICALLY RECONNECT THE CONTROL CIRCUIT IN CASE OF CIRCUIT BREAKER TRIP ON ONE PUMP. H-O-A SWITCHES AND RUN LIGHTS SHALL BE SUPPLIED FOR ALL PUMPS. TERMINAL STRIP SHALL BE PROVIDED FOR CONNECTING PUMP AND CONTROL WIRES. ELAPSED TIME METERS SHALL BE FURNISHED FOR ALL PUMPS AND INSTALLED IN PANEL. THE PANEL SHALL INCLUDE INTRINSICALLY-SAFE BARRIERS FOR EACH FLOAT AND LEVEL TRANSMITTER, DRY CONTACTS FOR CONNECTION TO THE VILLAGE OF JOHNSBURG SCADA SYSTEM, POWER FEED FOR THE EQUIPMENT & ACCESSORIES. THE CONTROL PANEL SHALL ALSO CONTAIN PHASE, SURGE, VOLTAGE PROTECTION, A CONTROLLER-BASED LEVEL MANAGEMENT SYSTEM, AND ACCESSORIES AS DESCRIBED BELOW.

THE CONTROL PANEL AND ALL ABOVE MENTIONED EQUIPMENT SHALL BE MOUNTED INSIDE THE NEMA-3R TRAFFIC ENCLOSURE AS SHOWN ON THE PLANS. IN ADDITION TO THE CONTROL PANEL, THE TRAFFIC ENCLOSURE SHALL ALSO HOUSE AN AUTOMATIC TRANSFER SWITCH, POWER DISTRIBUTION PANEL, SCADA/TELEMETRY PANEL, MAIN DISCONNECT SWITCHES FOR POWER SOURCES, LIGHTING PANEL AND TRANSFORMER, LIGHTS, HEATER(S), EXHAUST FANS, GFI CONVENIENCE OUTLETS, BATTERY BACK-UP SYSTEM WITH BATTERY CHARGER, NEMA RATED STARTERS WITH SOLID STATE OVERLOADS, NEMA FULL SIZE CIRCUIT BREAKERS FOR MAIN POWER, ETC. PER THE VILLAGE OF JOHNSBURG STANDARDS, AND AN EXTERIOR ALARM LIGHT.

B. TELEMETRY:

A SCADA PANEL SHALL BE USED TO CONTACT THE Village's DESIGNATED AREA DURING ALARM CONDITIONS. THE PANEL SHALL BE CAPABLE OF REPORTING ALARMS THROUGH THE EXISTING Village SYSTEM. THE CONTRACTOR SHALL BE RESPONSIBLE FOR INTEGRATING THIS PANEL INTO THE Village SYSTEM. THE CONTRACTOR SHALL UTILIZE ADVANCED AUTOMATION & CONTROLS INC., THE Village's SYSTEM INTEGRATOR AND PURCHASE THE SCADA PANEL FROM THIS PROVIDER. THE SYSTEM SHALL BE PLC BASED UTILIZING AN "OPEN" ARCHITECTURE PROTOCOL. RADIO COMMUNICATIONS SHALL BE UTILIZED TO TRANSMIT AND RECEIVE DATA FROM EACH LOCATION. THE FOLLOWING IS A LISTING OF THE "CONTACTS", THAT AT A MINIMUM, THE SYSTEM SHALL BE CAPABLE OF REPORTING BACK TO THE Village:

- PUMP RUN SIGNALS (2 REQUIRED)
- POWER FAILURE SIGNAL
- PUMP FAILURE SIGNALS (2 REQUIRED)
- HIGH WET WELL LEVEL
- VALVE VAULT HIGH LEVEL ALARM
- LOW WET WELL LEVEL
- GENERATOR RUN SIGNAL AND GENERATOR FAIL TO RUN SIGNAL
- GENERATOR FAIL SIGNAL
- INTRUSION ALARM (ACCESS HATCH DOORS)
- HOUR METER DATA (2 SIGNALS)
- PUMP OVER TEMPERATURE
- POWER FAULT SIGNAL
- PUMP ELAPSED RUNTIMES FOR DAY AND MONTH
- PUMP SEAL FAILURE
- NUMBER OF STARTS PER PUMP FOR DAY AND MONTH

C. CONTROL PANEL:

THE PUMPING SYSTEM SHALL BE CONTROLLED BY PLC BASED CONTROLLER. PLC SHALL MONITOR AND CONTROL STATION FUNCTIONALITY. ALL COMPONENTS SHALL BE ENCLOSED IN A NEMA TYPE 1 ENCLOSURE. CONTROL PANEL SHALL BE POWERED BY A SEPARATE 115 VAC POWER SOURCE. THE CONTROL PANEL SHALL BE COMPLETELY PREWIRED AND TESTED AT THE FACTORY. ALL CUSTOMER CONNECTIONS SHALL BE WIRED TO INDIVIDUALLY NUMBERED TERMINALS AND WIRES SHALL BE NUMBERED AT BOTH ENDS FOR EASE OF TROUBLESHOOTING. ALARM LIGHT TO BE MOUNTED ON THE CONTROL PANEL TO PROVIDE VISUAL NOTIFICATION OF AN ALARM CONDITION. AN EXTRA LEVEL TRANSDUCER SHALL BE PROVIDED BY THE CONTRACTOR FOR EACH STATION.

REFERENCED STANDARDS:

- NATIONAL ELECTRICAL MANUFACTURERS ASSOCIATION (NEMA)
- NEMA 250-1991, ENCLOSURES FOR ELECTRICAL EQUIPMENT (1000 VOLTS MAXIMUM)
- INSTITUTE OF ELECTRICAL AND ELECTRONIC ENGINEERS
- ANSI / IEEE C37.90, SURGE WITHSTAND CAPABILITY
- FEDERAL COMMUNICATIONS COMMISSION
- FCC PART 15 SUBPART J, CLASS A, RADIO EMISSIONS
- UNDERWRITERS LABORATORY
- UL 508, INDUSTRIAL CONTROL EQUIPMENT

THE CONTROL SYSTEM SHALL OPERATE PUMP(S) AS NECESSARY TO MAINTAIN THE WET WELL LEVEL AS SET BY THE OPERATOR. THE SYSTEM SHALL OPERATE AS A DUPLEX SYSTEM. THE MICROPROCESSOR BASED CONTROLLER SHALL COORDINATE OPERATIONAL INPUT SIGNALS INCLUDING THE SYSTEM SET POINT, OPERATOR

SELECTOR SWITCH POSITIONS, INDICATOR LIGHTS, AND ALARMS. THE CONTROLLER SHALL COORDINATE PUMP OPERATION, ALTERNATION, AND SYSTEM ALARM. THE CONTROLLER SHALL BE RESPONSIVE TO THE WET WELL LEVELS TO CONTROL THE SYSTEM. AN LED LEVEL INDICATOR SHALL SHOW LIQUID LEVEL, PUMP ON, OFF AND HIGH/LOW WATER ALARM SET POINTS. ALARM AND OVERRIDE STAGING SET POINTS SHALL BE PROGRAMMED AS A DEVIATION ABOVE AND BELOW THE SET POINTS.

PROVIDE FLOAT SWITCH BACK UP TO PRIMARY LEVEL CONTROLS. ON SUMP LEVEL RISE LOWER SWITCH SHALL FIRST BE ENERGIZED, THEN UPPER LEVEL SWITCH SHALL NEXT ENERGIZE AND START LEAD PUMP. WITH LEAD PUMP OPERATING, SUMP LEVEL SHALL LOWER TO LOW SWITCH TURN-OFF SETTING AND PUMP SHALL STOP. LEAD AND LAG PUMP(S) SHALL ALTERNATE ON EACH SUCCESSIVE PUMPING CYCLE. IF SUMP LEVEL CONTINUES TO RISE WHEN LEAD PUMP IS OPERATING, OVERRIDE SWITCH SHALL ENERGIZE AND START LAG PUMP. BOTH LEAD PUMP AND LAG PUMP SHALL OPERATE TOGETHER UNTIL LOW LEVEL SWITCH TURNS OFF BOTH PUMPS. IF SUMP LEVEL CONTINUES TO RISE WHEN LEAD AND LAG PUMP ARE OPERATING, ALARM SWITCH SHALL ENERGIZE AND SIGNAL THE ALARM. IF ONE PUMP SHOULD FAIL FOR ANY REASON, THE OTHER PUMP SHALL OPERATE ON THE OVERRIDE CONTROL. ALL LEVEL SWITCHES SHALL BE ADJUSTABLE FOR LEVEL SETTING FROM THE SURFACE. THE CAGED HIGHWATER ALARM LIGHT/STROBE SHALL BE MOUNTED ON THE TRAFFIC ENCLOSURE. UNDER ALARM CONDITIONS THE LIGHT SHALL FLASH. ALARM LIGHT SHALL HAVE A REST BUTTON. IN CASE OF POWER FAILURE, ALARM LIGHT SHALL BE POWERED BY A GEL-CELL BATTERY.

CONTROL PANEL SHALL INCLUDE PUMP MOTOR SEAL FAIL SENSORS AND MOTOR THERMAL SHUT DOWN CIRCUITS IN ACCORDANCE WITH THE PUMP MANUFACTURERS RECOMMENDATIONS. THE SYSTEM SHALL OPERATE COMPLETELY UNATTENDED, AND SHALL HAVE RUNNING, LOCK-OUT, AND FAILURE CONTACTS FOR OPTIONAL CONNECTION TO SUPERVISORY CONTROLS.

- INTRINSICALLY SAFE CIRCUIT EXTENSIONS SHALL BE PROVIDED FOR THE LEVEL SENSING TRANSDUCER AND FLOAT SWITCHES.
- ALL INPUTS AND OUTPUTS SHALL SURVIVE ANSI/IEEE C37.90 SURGE WITHSTAND CAPABILITY TESTS WITHOUT DAMAGE.

CONTROL PANEL - LED'S LOCATED ON THE CONTROL PANEL

PANEL CONTROLS AND INDICATORS SHALL INCLUDE:

- RUN LIGHT FOR PUMP
- PUMP HAND/OFF/AUTOMATIC SELECTORS
- PUMP SEAL FAIL LIGHT
- PUMP OVER TEMPERATURE LIGHT
- PUMP FAIL (FROM PUMP MOTOR STARTERS)
- SYSTEM ALARM LIGHT & CONTACTS
- OPERATOR INTERFACE

- THE CONTROL PANEL MANUFACTURER SHALL BE LISTED WITH UNDERWRITERS LABORATORIES UNDER UL 508 (TYPE L) LISTING CATEGORY FOR THE MANUFACTURE OF CONTROL EQUIPMENT. THE CONTROL PANEL SHALL CONTAIN UL LISTED COMPONENTS WHEREVER PRACTICAL. THE ENTIRE CONTROL PANEL ASSEMBLY SHALL BE APPROVED BY UL AND LABELED TO THAT EFFECT.

D. LEVEL TRANSDUCER (PRIMARY CONTROL):

A VILLAGE'S RECOMMENDED LEVEL TRANSDUCER IS TO BE INSTALLED AND EXTRA LEVEL TRANSDUCER IS TO BE PROVIDED TO THE VILLAGE OF JOHNSBURG.

E. FLOAT SWITCH (BACK-UP CONTROL):

FLOAT SWITCHES ARE TO BE STANDARD PUMP MANUFACTURER'S FLOAT SWITCHES. POWER CORD SHALL BE 2 CONDUCTOR #16 FLEXIBLE CORD TYPE SJOW-A WATER AND OIL RESISTANT, 300 VOLT. SWITCH RATING SHALL BE 2 AMPS AT 115 OR 230 VAC. FLOAT SWITCH OPERATING TEMPERATURES TO 70°C (160°F). PROVIDE SUPPORT BRACKETS AS REQUIRED OR SHOWN ON THE DRAWINGS.

F. HIGH WATER ALARM:

THE FACE OF THE CONTROL PANEL SHALL HAVE INDICATOR LIGHTS FOR EACH OF THE FOLLOWING ALARMS: WET WELL HIGH WATER LEVEL, ANY PUMP FAILURE, POWER FAILURE, AND FLOODING IN EITHER THE VALVE VAULT OR THE METER VAULT. CONTACTS SHALL BE SUPPLIED FOR CONNECTING THESE AND OTHER ALARMS TO THE TELEMETRY PANEL.

G. CIRCUIT BREAKERS:

THE CONTROL PANEL SHALL HAVE INDIVIDUAL CIRCUIT BREAKERS TO POWER EACH SYSTEM, INCLUDING BUT NOT LIMITED TO: PUMP CONTROL SYSTEM, SCADA SYSTEM, PUMP #1, PUMP #2, GENERATOR COOLANT HEATER, GENERATOR BATTERY CHARGER, SUMP PUMP, GFI CONVENIENCE RECEPTACLE, ETC.

H. EXTERIOR SECOND PARTY CONNECTIONS:

PROVIDE SUB-PANELS, CUT-OUTS AND HOLES AS NECESSARY TO MOUNT INTERNAL SECOND PARTY ACCESSORIES AND CONNECT TO EXTERNALLY MOUNTED DEVICES AND CONDUIT. PROVIDE WATER-TIGHT HUBS AND MATING MATERIALS. PRE-WIRE DEVICES FOR FAST CONNECTION IN THE FIELD. EXTERNAL WIRING AND WIRING TO SECOND PARTY ACCESSORIES SHALL BE TERMINATED AT TERMINAL BLOCKS. PROVIDE 10% SPARE TERMINALS. CONTRACTOR IS RESPONSIBLE FOR PROVIDING WIRING BETWEEN INTERNAL ACCESSORIES AND EXTERNAL DEVICES PROVIDE ADDITIONAL BRACING WITHIN CONTROL PANEL WHERE OTHER ENCLOSURES ARE MOUNTED TO THE EXTERIOR.

I. ELECTRICAL EQUIPMENT AND CONDUIT SCHEDULE:

PRIOR TO FURNISHING AND INSTALLING CONDUIT, CONFIRM PROPOSED SIZES/COUNT AND CONFIGURATION WITH VILLAGE REPRESENTATIVE. ALL CONDUIT SHALL BE PVC COATED GALVANIZED HEAVY WALL CONDUIT.

CIRCUITS TO WET WELL: (5 CONDUITS PROPOSED)

- PUMP LEADS: CONDUIT DIA. 2" (2 CONDUITS PROPOSED)
  - PUMP NO. 1 - 2" DIA. CONDUIT
  - PUMP NO. 2 - 2" DIA. CONDUIT
- FLOATS: CONDUIT DIA. 2" (1 CONDUIT PROPOSED)
- LEVEL TRANSMITTER: CONDUIT DIA. 1" (1 CONDUIT PROPOSED)
- SPARE: CONDUIT DIA. 2" (1 CONDUIT PROPOSED)

WET WELL CONDUITS SHALL BE TERMINATED APPROX. 4" INSIDE THE WET WELL STRUCTURE, WITH A THREADED PVC BUSHING, TO ACCOMMODATE THICKNESS AND ADHERENCE OF THE PROPOSED LINING SYSTEM.

CIRCUITS TO VALVE VAULT: (2 CONDUITS PROPOSED)

SUMP PUMP FROM CONTROL PANEL ENCLOSURE TO VALVE VAULT: (2 CONDUITS PROPOSED)

- SUMP PUMP: CONDUIT DIA. 3/4" (1 CONDUIT PROPOSED)
- SPARE: CONDUIT DIA. 3/4" (1 CONDUIT PROPOSED)
  - a. STUB METAL CONDUITS MINIMUM 6" INTO VALVE VAULT STRUCTURE.
  - b. UPPER CONDUIT: SUMP PUMP POWER, TERMINATE AT J-BOX.
  - c. LOWER CONDUIT: SPARE, TERMINATE WITH PVC CAP.

SUMP PUMP, VALVE VAULT INTERIOR: CONDUIT DIA. 1/2" (1 CONDUIT PROPOSED)

- a. CONDUIT: SCH 80 GREY PVC CONDUIT AND RELATED PVC FITTINGS. SUPPORT CONDUIT WITH HEAVY DUTY STAINLESS STEEL ONE-HOLE CONDUIT STRAPS, OR APPROVED EQUAL STAINLESS STEEL OR NON-METALLIC SUPPORTS, INSTALLED AT 24" MINIMUM CENTER TO CENTER.
- b. OUTLET BOX: NON-METALLIC (GREY PLASTIC) HEAVY DUTY 1 GANG WITH WHILE-IN-USE WEATHERPROOF COVER.
- c. JUNCTION BOX: NON-METALLIC (GREY PLASTIC) HEAVY DUTY 1 GANG WITH WEATHERPROOF COVER.
- d. OUTLET: LEVITON INDUSTRIAL GRADE HEAVY DUTY OR EQUIVALENT. OUTLET SHALL BE WIRED TO GROUND AT THE CONTROL ENCLOSURE.
- e. FASTENER HARDWARE: ALL FASTENING/ANCHORING MATERIALS SHALL BE STAINLESS STEEL.

CIRCUITS TO FUTURE GENERATOR AND LIGHT POLE: (3 CONDUIT PROPOSED)

- GENERATOR: CONDUIT DIA. 2" (2 CONDUIT PROPOSED)
- LIGHT POLE: CONDUIT DIA. 1" (1 CONDUIT PROPOSED)

CONDUIT BURY DEPTHS SHALL MEET THE VILLAGE'S ELECTRICAL CODE REQUIREMENTS. CONDUIT LOCATION AND ORIENTATION SHALL BE COORDINATED WITH THE VILLAGE AND THE VILLAGE'S INTEGRATOR. CONDUITS SHALL BE INSTALLED AS REQUIRED BY THE ELEVATION, LOCATION, ORIENTATION, AND BASE DIMENSIONS OF THE CONTROL CABINET.

	EXISTING	PROPOSED
SANITARY MANHOLE		
STORM MANHOLE		
STORM CATCH BASIN		
STORM INLET		
FLARED END SECTION		
LIGHT POLE		
STREET SIGN		
REGULATORY SIGN		
UTILITY POLE		
UTILITY BOX		
MAILBOX		
WELL		
SANITARY SEWER		
STORM SEWER		
CULVERT		
SANITARY FORCEMAIN		
STORM UNDERDRAIN		
ELECTRIC LINE		
TELEPHONE LINE		
GAS LINE		
CABLE TV LINE		
R.O.W. (RIGHT OF WAY)		
E.O.P. (EDGE OF PAVEMENT)		
DRIVEWAY		
TREELINE		
TREE		
CONTOURS		
FENCE		
EROSION CONTROL FENCE (QUANTITY SPECIFIED ON PLANS)		
FRONT OF HOUSE (TYPICAL)		

FOR BID

STANDARD ABBREVIATIONS

- B-B - BACK TO BACK OF CURB
- B.C. - BACK OF CURB
- B.O.C. - BACK OF CURB
- B.S.L. - BUILDING SETBACK LINE
- C.B. - STORM CATCH BASIN
- C.E. - COMMONWEALTH EDISON CO.
- D.E. - DRAINAGE EASEMENT
- E-E - EDGE TO EDGE OF PAVEMENT
- E.O.P. - EDGE OF PAVEMENT
- E.O.S. - EDGE OF SHOULDER
- E.P. - EDGE OF PAVEMENT
- E.S. - EDGE OF SHOULDER
- F.E.S. - FLARED END SECTION
- I.B.T. - ILLINOIS BELL TELEPHONE CO.
- L.E. - LANDSCAPE EASEMENT
- M.H. - MANHOLE (TYPE SPECIFIED ON PLANS)
- R.C.M.E. - ROAD CONSTRUCTION & MAINTENANCE EASEMENT
- R.O.W. - RIGHT OF WAY
- S.R.L. - SEPTIC RESTRICTION LINE
- T.B.F. - TRENCH BACKFILL
- T.C. - TOP OF CURB
- T.C.E. - TEMPORARY CONSTRUCTION EASEMENT
- T.O.B. - TOP OF BERM
- T.O.C. - TOP OF CURB
- U.E. - UTILITY EASEMENT

PROJECT LEGENDS

- DESIGNATES PROPOSED HMA PAVEMENT REMOVAL AND REPLACEMENT (CLASS D PATCHING) (FULL DEPTH)
- DESIGNATES HMA DRIVEWAY REMOVAL AND REPLACEMENT
- DESIGNATES CONC. DRIVEWAY REMOVAL AND REPLACEMENT
- DESIGNATES AGGREGATE DRIVEWAY/SHOULDER REMOVAL AND REPLACEMENT
- DESIGNATES CONC. SIDEWALK REMOVAL AND REPLACEMENT
- DESIGNATES DISTURBED AREA SEED W/ IDOT CLASS 1A MIX (SEE RESTORATION SPECIFICATIONS)
- DESIGNATES DISTURBED AREA SEED W/ IDOT CLASS 4F MIX (SEE RESTORATION SPECIFICATIONS)
- DESIGNATES CURB AND GUTTER REMOVAL AND REPLACEMENT
- DESIGNATES EROSION CONTROL MEASURE (SEE SHEET C-18 FOR EROSION CONTROL DETAILS)
- DESIGNATES SILT FILTER FENCE (LIMITS OF GRADING) (SEE SPECIFIED SHEET FOR DETAILS.)
- SAWCUT (FULL DEPTH)
- DESIGNATES TREE AND BRUSH REMOVAL (SEE SHEET FOR SIZE AND QUANTITY)
- DESIGNATES TREE TRUNK & ROOT PROTECTION (POTENTIAL ROOT PRUNING REQUIRED)
- DESIGNATES SANITARY SEWER TAG

EROSION CONTROL NOTES:

- A. SEQUENCE OF CONSTRUCTION / EROSION CONTROL MEASURES
  1. INSTALLATION OF SEDIMENTATION AND EROSION CONTROL MEASURES.
  2. SITE CLEARING AND TOPSOIL STRIPPING/ STOCKPILE.
  3. EXCAVATION AND MASS GRADING.
  4. INSTALLATION OF LIFT STATION, VALVE VAULT AND FORCEMAIN
  5. FINAL GRADING / PAVING / LANDSCAPING
- B. ALL EROSION AND SEDIMENT CONTROL PRACTICES SHALL BE MAINTAINED AND REPAIRED AS NEEDED TO ENSURE EFFECTIVE PERFORMANCE OF THE REQUIRED EROSION CONTROL MEASURES.
- C. ALL EROSION CONTROL MEASURES SHALL BE DISPOSED OF WITHIN 30 DAYS OF FINAL STABILIZATION OF THE SITE.
- D. ALL EROSION AND SEDIMENT CONTROL WORK SHALL CONFORM TO THE ILLINOIS URBAN MANUAL STANDARDS AND PROCEDURES FOR EROSION CONTROL.

DRAWN BY: HCM	JOB DATE: 2022	BAR IS ONE INCH ON OFFICIAL DRAWINGS.
APPROVED: SGM	JOB NUMBER: 210915	0
CAD DATE: 1/9/2024 1:33:03 PM		IF NOT ONE INCH, ADJUST SCALE ACCORDINGLY.
CAD FILE: \\hrgreen.com\HRC\Data\2021\210915\CAD\DWGS\C\210915_CG100_General Notes.dwg		

NO.	DATE	BY	REVISION DESCRIPTION

ILLINOIS DESIGN FIRM # 184.001322  
 1391 CORPORATE DRIVE, SUITE 203  
 McHENRY, ILLINOIS 60050  
 PHONE: 815.385.1778 | TOLL FREE: 800.728.7805  
 FAX: 815.385.1781 | HRGreen.com

EAST SERVICE AREA PHASE 1  
 SANITARY SEWER EXTENSION  
 VILLAGE OF JOHNSBURG  
 JOHNSBURG, ILLINOIS

FOR BID  
 GENERAL NOTES AND SPECS

SHEET NO.  
 CG004

xrefs: xg-1-dn01

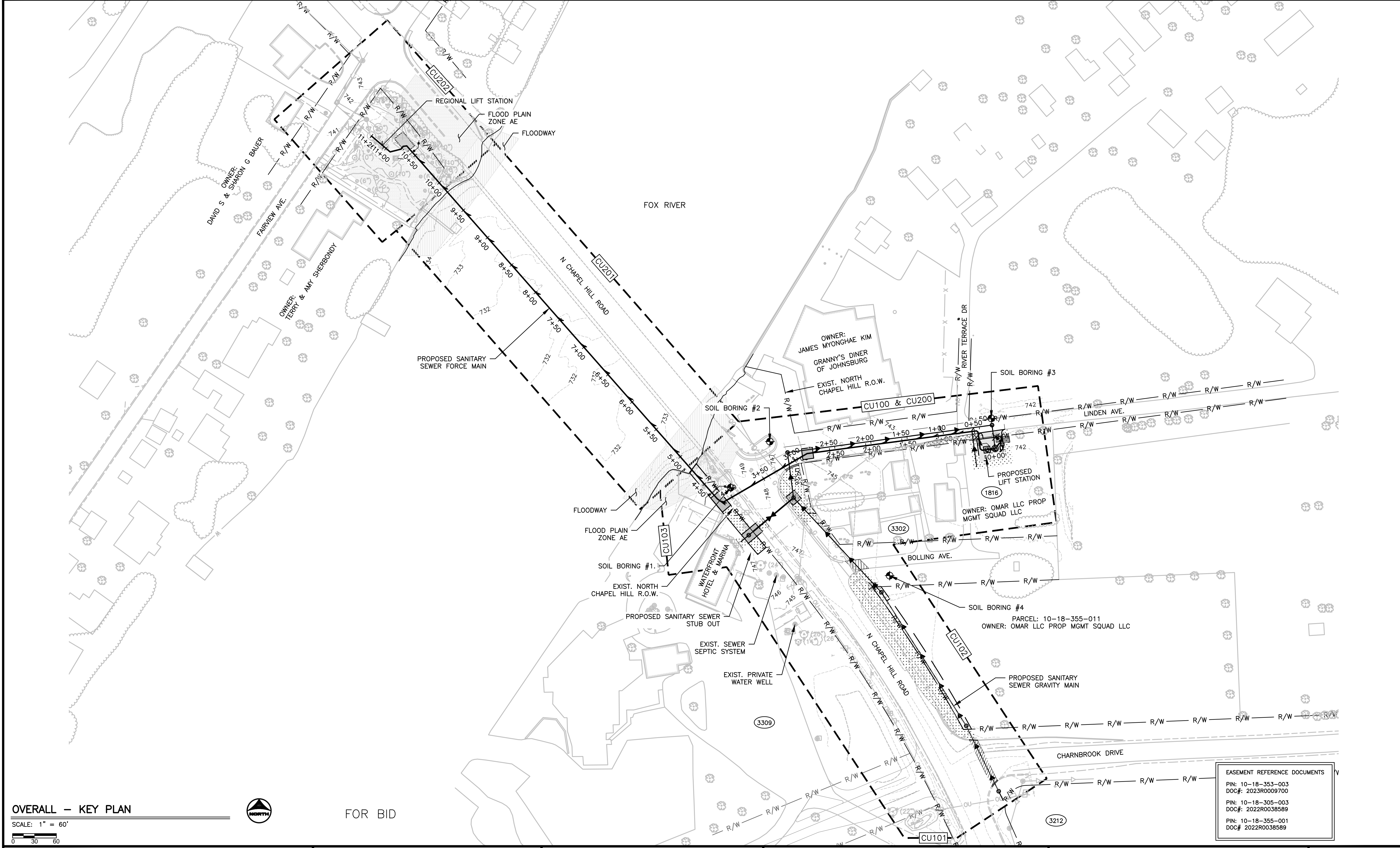

**OVERALL - KEY PLAN**

SCALE: 1" = 60'  
 0 30 60



FOR BID

EASEMENT REFERENCE DOCUMENTS	
PIN: 10-18-353-003	DOC#: 2023R009700
PIN: 10-18-305-003	DOC#: 2022R0038589
PIN: 10-18-355-001	DOC#: 2022R0038589

DRAWN BY: HCM	JOB DATE: 2022	BAR IS ONE INCH ON OFFICIAL DRAWINGS: 1"
APPROVED: SGM	JOB NUMBER: 210915	IF NOT ONE INCH, ADJUST SCALE ACCORDINGLY.
CAD DATE: 1/9/2024 1:43:54 PM		
CAD FILE: \\hrgreen.com\HRG\Data\2021\210915\CAD\Dwgs\C\210915_CG100_Overall Project Key Map.dwg		

NO.	DATE	BY	REVISION DESCRIPTION
1	1/5/24	NF	ADDENDUM #3

**HRGreen**  
 ILLINOIS DESIGN FIRM # 184.001322  
 1391 CORPORATE DRIVE, SUITE 203  
 McHENRY, ILLINOIS 60050  
 PHONE: 815.385.1778 | TOLL FREE: 800.728.7805  
 FAX: 815.385.1781 | HRGreen.com

**EAST SERVICE AREA PHASE 1  
 SANITARY SEWER EXTENSION  
 VILLAGE OF JOHNSBURG  
 JOHNSBURG, ILLINOIS**

FOR BID  
 OVERALL KEY MAP

SHEET NO.  
**CG100**

X:\enr\sgf-1-dm01\210915\_CU\_S&N\210915\_Survey\210915\_CU\_LS\210915\_CU\_FM

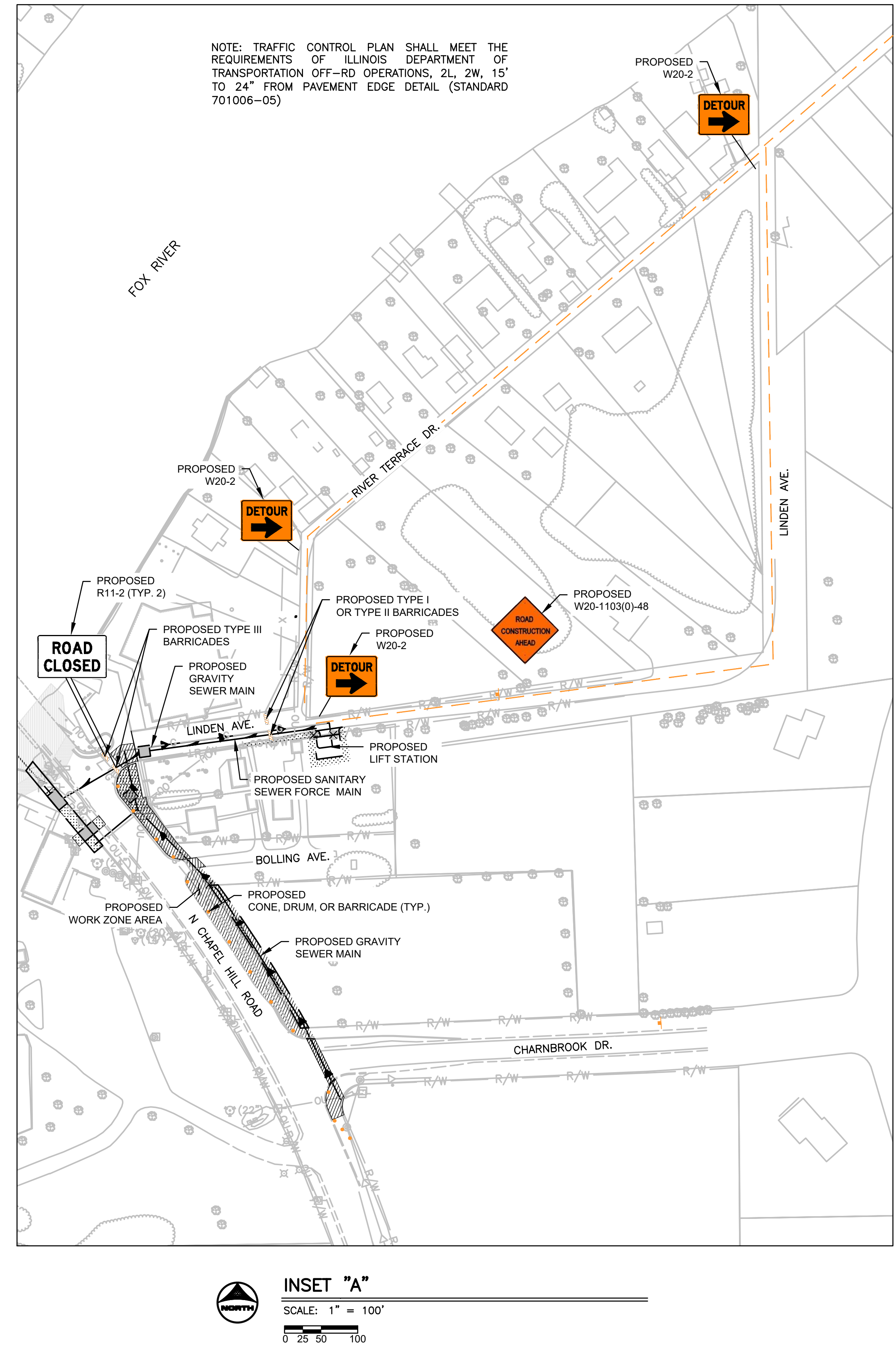
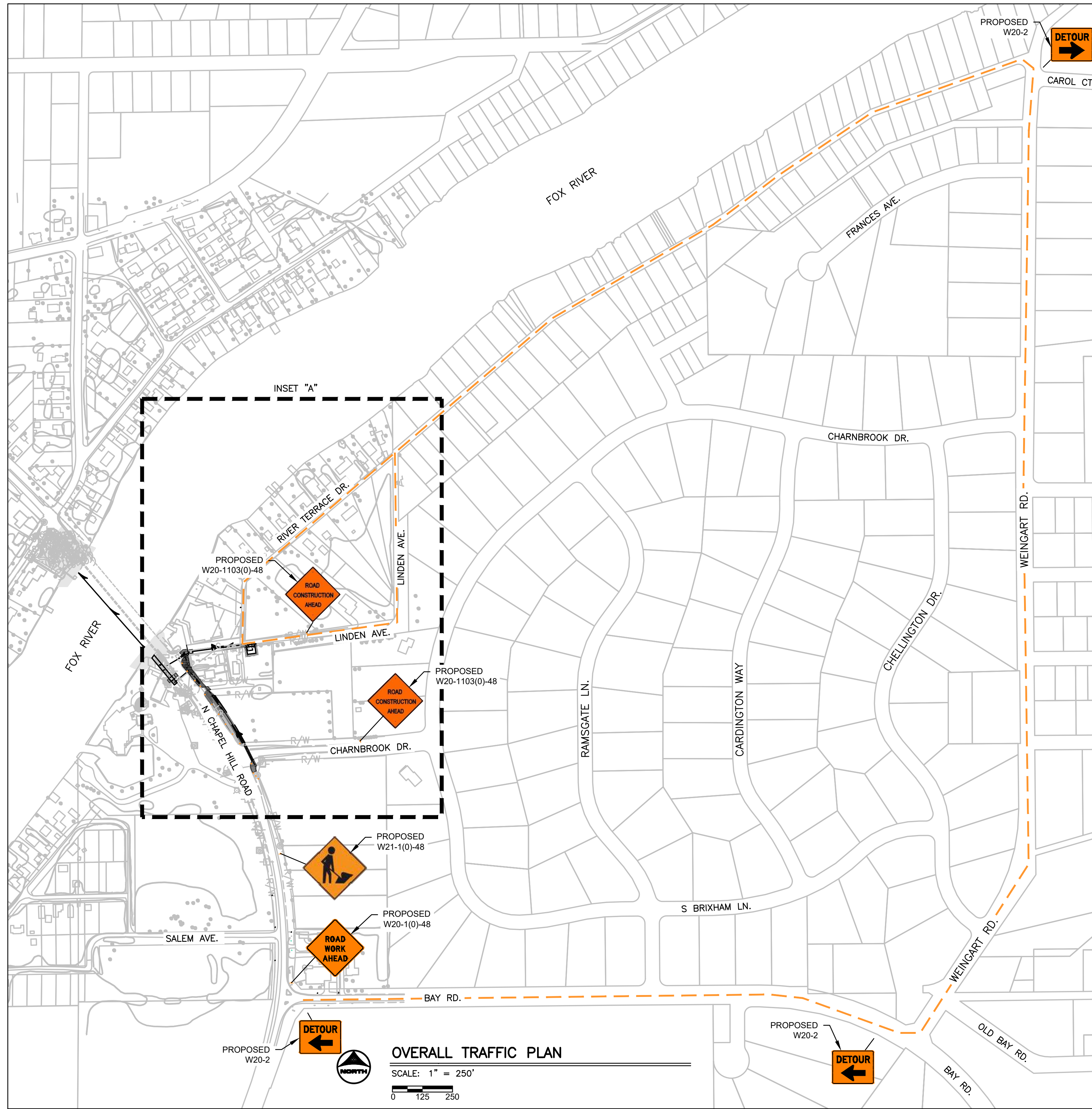

NOTE: TRAFFIC CONTROL PLAN SHALL MEET THE REQUIREMENTS OF ILLINOIS DEPARTMENT OF TRANSPORTATION OFF-RD OPERATIONS, 2L, 2W, 15' TO 24" FROM PAVEMENT EDGE DETAIL (STANDARD 701006-05)

Xref: xgt-1-dh01: 210915\_Survey; 210915\_Tax\_Parcels

DRAWN BY: HCM      JOB DATE: 2022  
 APPROVED: SGM      JOB NUMBER: 210915  
 CAD DATE: 1/9/2024 1:32:02 PM  
 CAD FILE: \\hrgreen.com\HRG\Data\2021\210915\CAD\Dwgs\C\210915\_Traffic Control Plan.dwg

BAR IS ONE INCH ON OFFICIAL DRAWINGS.  
 IF NOT ONE INCH, ADJUST SCALE ACCORDINGLY.

NO.	DATE	BY	REVISION DESCRIPTION

**HRGreen**  
 ILLINOIS DESIGN FIRM # 184.001322  
 1391 CORPORATE DRIVE, SUITE 203  
 McHENRY, ILLINOIS 60050  
 PHONE: 815.385.1778 | TOLL FREE: 800.728.7805  
 FAX: 815.385.1781 | HRGreen.com

**EAST SERVICE AREA PHASE 1  
 SANITARY SEWER EXTENSION  
 VILLAGE OF JOHNSBURG  
 JOHNSBURG, ILLINOIS**

FOR BID  
 OVERALL TRAFFIC PLAN

SHEET NO.  
**CG101**

**GRAVITY MAIN - PLAN VIEW  
STA. 0+00 TO 3+77.58**

SCALE: 1" = 20'  
0 5 10 20

**EASEMENT REFERENCE DOCUMENTS**  
 PIN: 10-18-353-003  
 DOC#: 2023R0009700  
 PIN: 10-18-305-003  
 DOC#: 2022R0038589  
 PIN: 10-18-355-001  
 DOC#: 2022R0038589

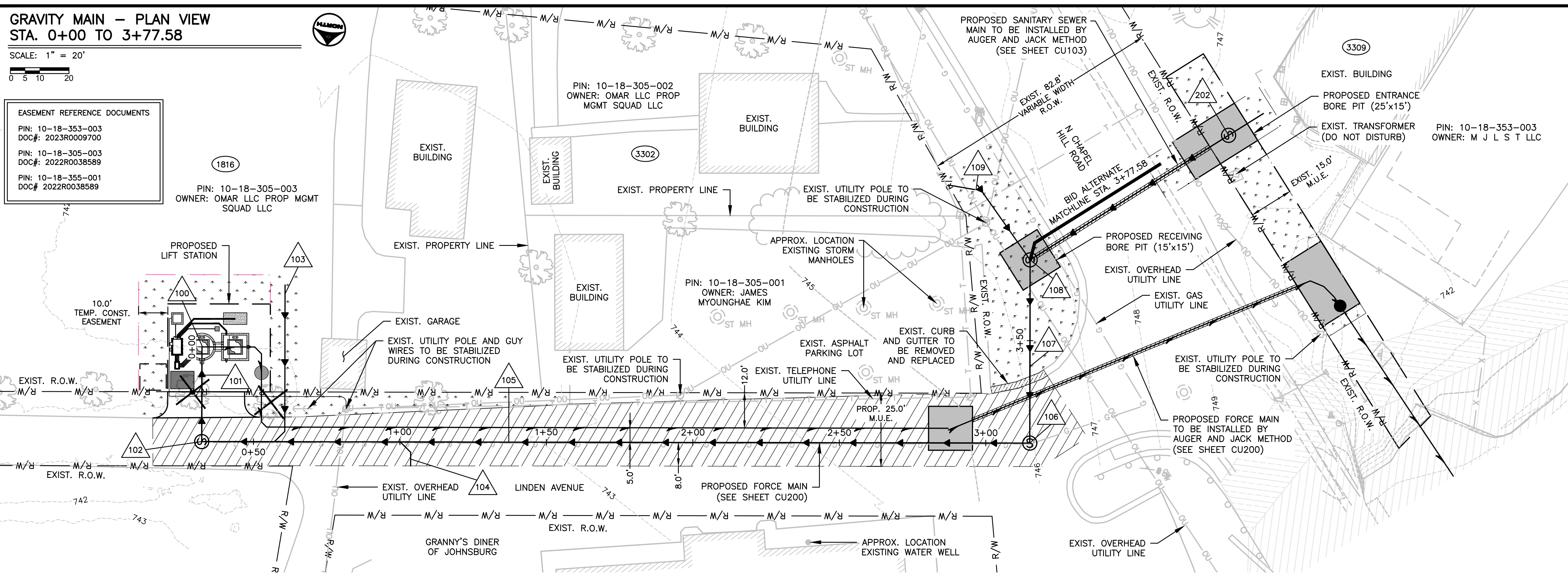

#	SANITARY SEWER TAGS
100	8" WET WELL STA: 0+00 RIM: 742.50' INV. 10": 726.00'
101	10" ASTM D3034 SDR26 PVC LENGTH: 29 L.F. SLOPE: 1.00%
102	4" SAN. MANHOLE STA: 0+32.33 RIM: 742.23' INV. 10": 726.28' (W) INV. 10": 726.28' (S)
103	6" ASTM D3034 SDR26 PVC LENGTH: 50 L.F. SLOPE: 1.00%
104	6" ASTM D3034 SDR26 PVC LENGTH: 10 L.F. SLOPE: 10.00%
105	10" AWWA C900 DR18 PVC LENGTH: 283 L.F. SLOPE: 0.50%
106	4" SAN. MANHOLE STA: 3+15.02 RIM: 745.94' INV. 10": 727.69' (SW) INV. 10": 727.69' (S)
107	10" ASTM D3034 SDR26 PVC LENGTH: 63 L.F. SLOPE: 0.50%
108	4" SAN. MANHOLE STA: 3+77.58 RIM: 746.56' INV. 10": 728.00' (NW) INV. 10": 728.00' (SE) INV. 8": 729.00' (SW) INV. 6": 738.56' (INSIDE DROP)
109	6" ASTM D3034 SDR26 PVC (INSIDE DROP) LENGTH: 40 L.F. SLOPE: 1.00%

- BORING NOTES:**
- ALL BORES UNDER NORTH CHAPEL HILL ROAD SHALL BE CONSTRUCTED BY AUGER AND JACK METHOD.
  - CONTRACTOR SHALL USE APPROVED AND APPROPRIATE METHODS FOR CONTAINING SOIL AT BORING AND RECEIVING PITS.

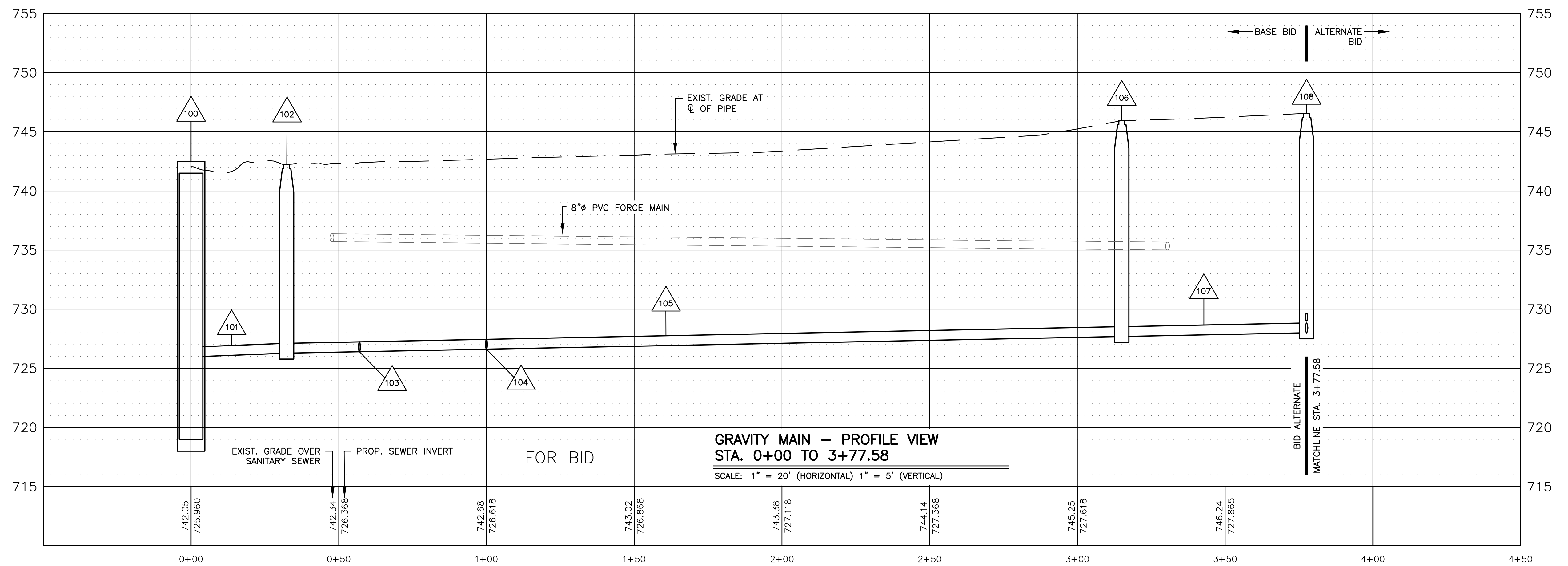

**GRAVITY MAIN - PROFILE VIEW  
STA. 0+00 TO 3+77.58**

SCALE: 1" = 20' (HORIZONTAL) 1" = 5' (VERTICAL)

DRAWN BY: HCM JOB DATE: 2022  
 APPROVED: SGM JOB NUMBER: 210915  
 CAD DATE: 1/9/2024 1:33:44 PM  
 CAD FILE: \\hrgreen.com\HRG\Data\2021\210915\CAD\Dwgs\C\210915\_CU100\_Gravity Sewer System.dwg

NO.	DATE	BY	REVISION DESCRIPTION
1	1/5/24	NF	ADDENDUM #3

ILLINOIS DESIGN FIRM # 184.001322  
 1391 CORPORATE DRIVE, SUITE 203  
 McHENRY, ILLINOIS 60050  
 PHONE: 815.385.1778 | TOLL FREE: 800.728.7805  
 FAX: 815.385.1781 | HRGreen.com

**EAST SERVICE AREA PHASE 1  
 SANITARY SEWER EXTENSION  
 VILLAGE OF JOHNSBURG  
 JOHNSBURG, ILLINOIS**

FOR BID  
 GRAVITY SEWER MAIN PLAN & PROFILE

SHEET NO.  
**CU100**

Xref: xg-1-dh01; 210915\_CU\_SAN; 210915\_CU\_LS; 210915\_Survey

OMITTED

xref: xgt-1-dh01; 210915\_CU\_S&N; 210915\_CU\_US; 210915\_Survey

DRAWN BY: HCM      JOB DATE: 2022  
APPROVED: SGM      JOB NUMBER: 210915  
CAD DATE: 1/9/2024 1:33:44 PM  
CAD FILE: \\hrgreen.com\HRG\Data\2021\210915\CAD\Dwgs\C\210915\_CU100\_Gravity Sewer System.dwg

BAR IS ONE INCH ON  
OFFICIAL DRAWINGS.  
0  1"  
IF NOT ONE INCH,  
ADJUST SCALE ACCORDINGLY.

NO.	DATE	BY	REVISION DESCRIPTION
1	1/5/24	NF	ADDENDUM #3



ILLINOIS DESIGN FIRM # 184.001322  
1391 CORPORATE DRIVE, SUITE 203  
McHENRY, ILLINOIS 60050  
PHONE: 815.385.1778 | TOLL FREE: 800.728.7805  
FAX: 815.385.1781 | HRGreen.com

**EAST SERVICE AREA PHASE 1  
SANITARY SEWER EXTENSION  
VILLAGE OF JOHNSBURG**  
JOHNSBURG, ILLINOIS

FOR BID  
GRAVITY SEWER MAIN PLAN & PROFILE  
(OMITTED)

SHEET NO.  
**CU101**



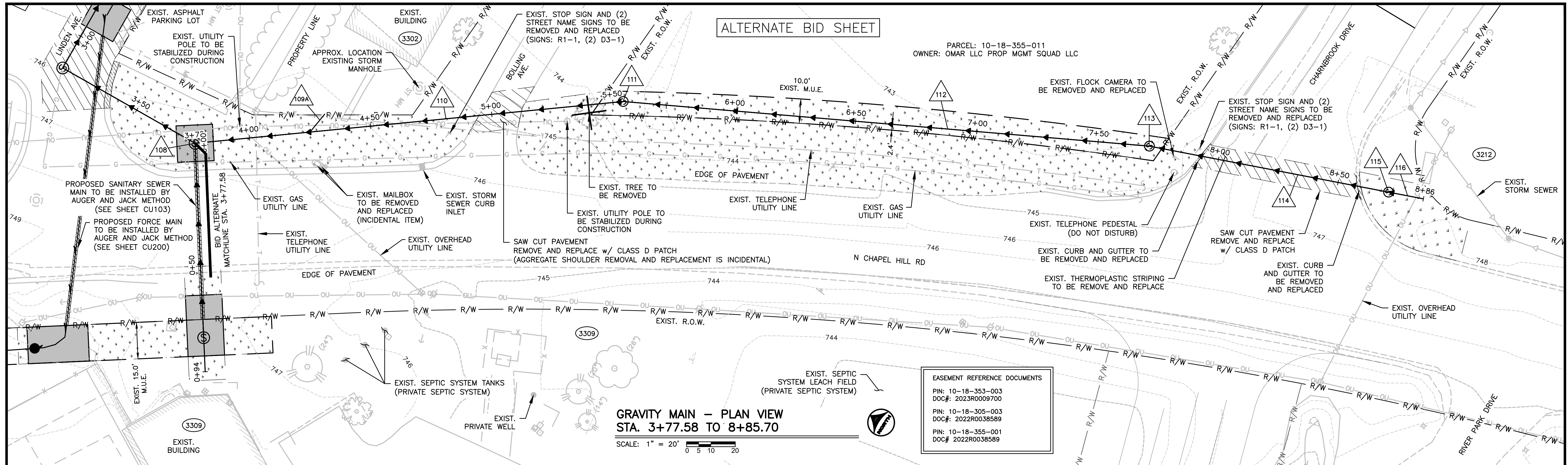

EASEMENT REFERENCE DOCUMENTS

PIN: 10-18-353-003
DOC#: 2023R0009700
PIN: 10-18-305-003
DOC#: 2022R0038589
PIN: 10-18-355-001
DOC#: 2022R0038589

**GRAVITY MAIN - PLAN VIEW  
STA. 3+77.58 TO 8+85.70**

SCALE: 1" = 20'  
0 5 10 20

**SANITARY SEWER TAGS**

108	4" SAN. MANHOLE STA.: 3+77.58 RIM: 746.56' INV. 10": 728.00' (NW) INV. 10": 728.00' (SE) INV. 8": 729.00' (SW)
109A*	6" ASTM D3034 SDR26 PVC LENGTH: 20 L.F. SLOPE: 1.00%
110*	10" ASTM D3034 SDR26 PVC LENGTH: 217 L.F. SLOPE: 0.50%
111*	4" SAN. MANHOLE STA.: 5+54.22 RIM: 743.28' INV. 10": 728.89' (NW) INV. 10": 728.89' (SE)
112*	10" ASTM D3034 SDR26 PVC LENGTH: 177 L.F. SLOPE: 0.50%
113*	4" SAN. MANHOLE STA.: 7+71.12 RIM: 743.07' INV. 10": 729.97' (NW) INV. 10": 729.97' (SE)
114*	10" ASTM D3034 SDR26 PVC LENGTH: 100 L.F. SLOPE: 0.50%
115*	4" SAN. MANHOLE STA.: 8+71.12 RIM: 747.53' INV. 10": 730.47' (NW) INV. 10": 730.47' (SE)
116*	10" ASTM D3034 SDR26 PVC LENGTH: 14 L.F. SLOPE: 0.50%

\* ALTERNATE BID ITEM

- BORING NOTES:**
- ALL BORES UNDER NORTH CHAPEL HILL ROAD SHALL BE CONSTRUCTED BY AUGER AND JACK METHOD.
  - CONTRACTOR SHALL USE APPROVED AND APPROPRIATE METHODS FOR CONTAINING SOIL AT BORING AND RECEIVING PITS.

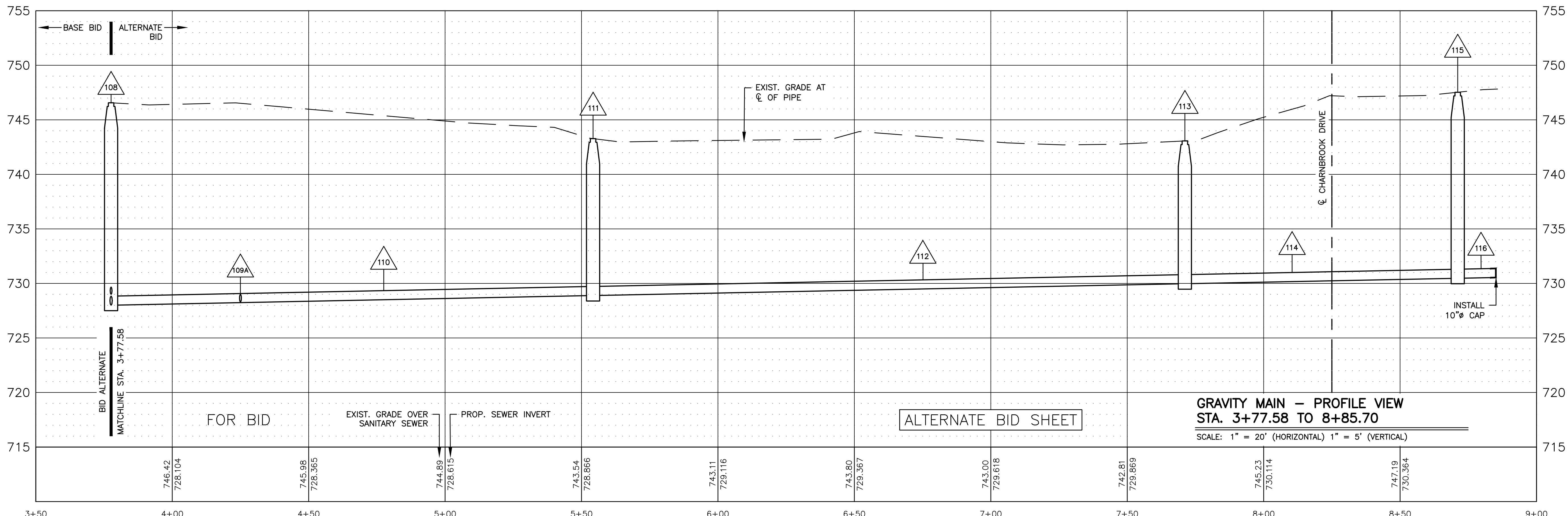

**GRAVITY MAIN - PROFILE VIEW  
STA. 3+77.58 TO 8+85.70**

SCALE: 1" = 20' (HORIZONTAL) 1" = 5' (VERTICAL)

DRAWN BY: HCM JOB DATE: 2022  
 APPROVED: SGM JOB NUMBER: 210915  
 CAD DATE: 1/9/2024 1:33:44 PM  
 CAD FILE: \\hrgreen.com\HRG\Data\2021\210915\CAD\Dwgs\C\210915\_CU100\_Gravity Sewer System.dwg

NO.	DATE	BY	REVISION DESCRIPTION
1	1/5/24	NF	ADDENDUM #3

ILLINOIS DESIGN FIRM # 184.001322  
 1391 CORPORATE DRIVE, SUITE 203  
 McHENRY, ILLINOIS 60050  
 PHONE: 815.385.1778 | TOLL FREE: 800.728.7805  
 FAX: 815.385.1781 | HRGGreen.com

**EAST SERVICE AREA PHASE 1  
SANITARY SEWER EXTENSION  
VILLAGE OF JOHNSBURG  
JOHNSBURG, ILLINOIS**

FOR BID  
 GRAVITY SEWER MAIN PLAN & PROFILE (A)

SHEET NO.  
**CU102**

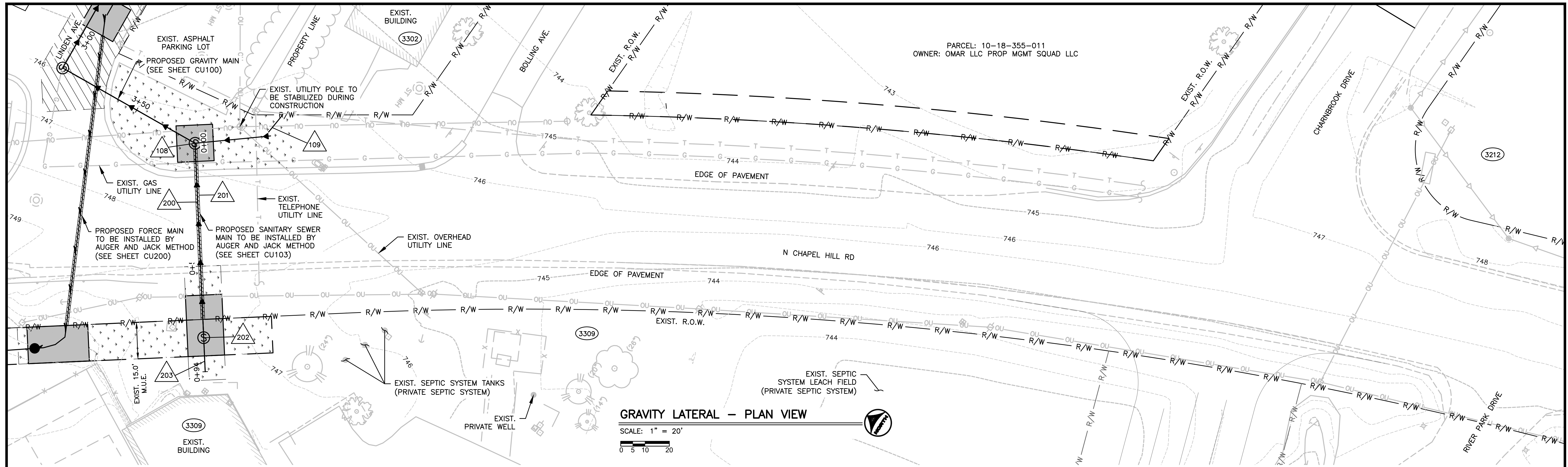

**GRAVITY LATERAL - PLAN VIEW**

SCALE: 1" = 20'  
0 5 10 20

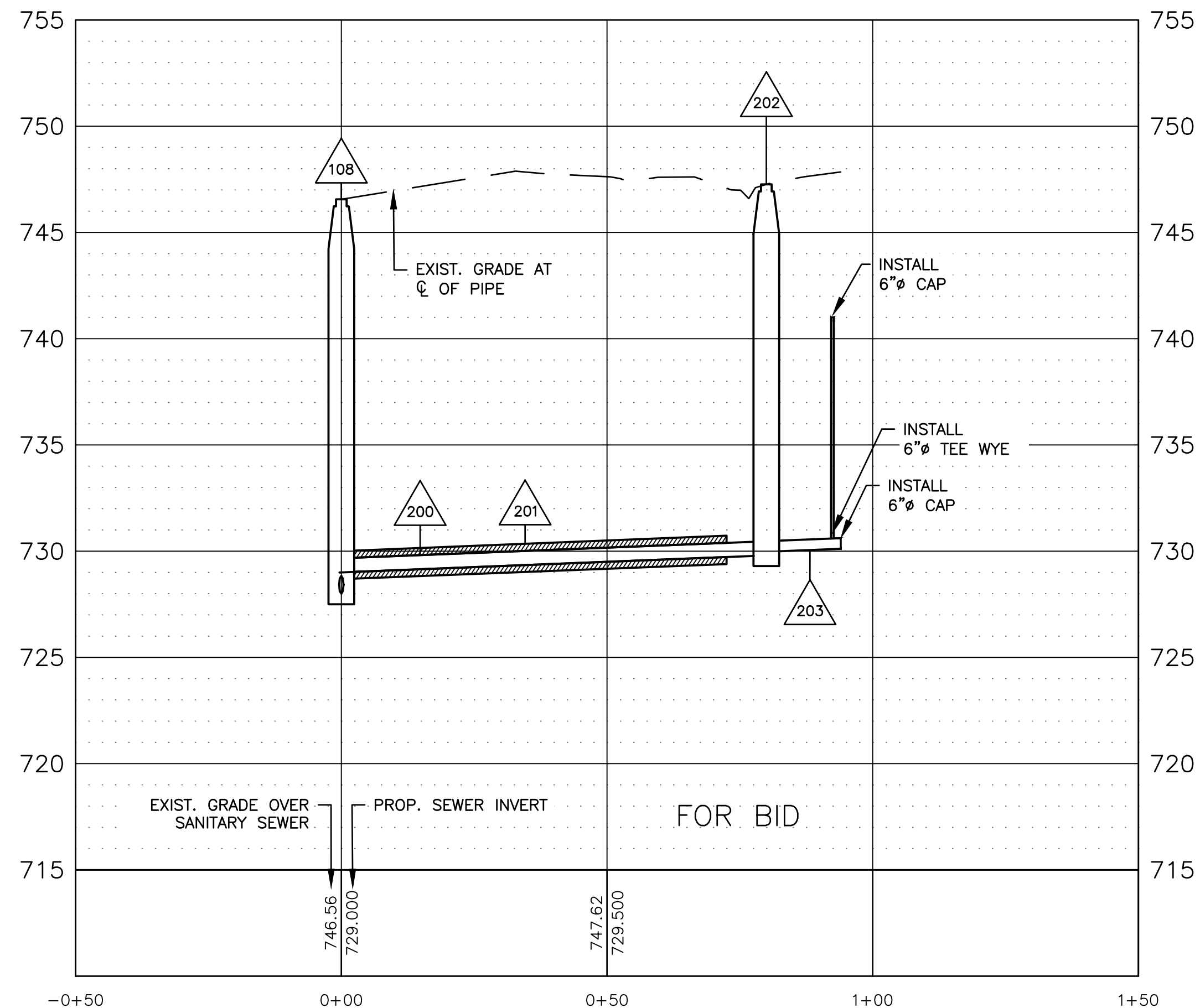

NO.	DESCRIPTION
108	4" SAN. MANHOLE STA.: 3+77.58 RIM: 746.56' INV. 10": 728.00' (NW) INV. 10": 728.00' (SE) INV. 8": 729.00' (SW) INV. 6": 738.56' (INSIDE DROP)
109	6" ASTM D3034 SDR26 PVC (INSIDE DROP) LENGTH: 40 L.F. SLOPE: 1.00%
200	8" ASTM D3034 SDR26 PVC LENGTH: 80 L.F. SLOPE: 1.00%
201	16" STEEL ENCASUREMENT PIPE LENGTH: 70 L.F. SLOPE: 1.00%
202	4" SAN. MANHOLE STA.: 0+80.00 RIM: 747.26' INV. 8": 729.80' (NW) INV. 6": 729.97' (SW)
203	6" ASTM D3034 SDR26 PVC LENGTH: 24 L.F. SLOPE: 1.00%

**BORING NOTES:**

- ALL BORES UNDER NORTH CHAPEL HILL ROAD SHALL BE CONSTRUCTED BY AUGER AND JACK METHOD.
- CONTRACTOR SHALL USE APPROVED AND APPROPRIATE METHODS FOR CONTAINING SOIL AT BORING AND RECEIVING PITS.

**EASEMENT REFERENCE DOCUMENTS**

PIN: 10-18-353-003  
DOC#: 2023R0009700  
PIN: 10-18-305-003  
DOC#: 2022R0038589  
PIN: 10-18-355-001  
DOC#: 2022R0038589

**GRAVITY LATERAL - PROFILE VIEW**  
STA. 0+00 TO 0+94

SCALE: 1" = 20' (HORIZONTAL) 1" = 5' (VERTICAL)

DRAWN BY: HCM JOB DATE: 2022  
APPROVED: SGM JOB NUMBER: 210915  
CAD DATE: 1/9/2024 1:33:44 PM  
CAD FILE: \\hrgreen.com\HRG\Data\2021\210915\CAD\Dwgs\C\210915\_CU100\_Gravity Sewer System.dwg

NO.	DATE	BY	REVISION DESCRIPTION
1	1/5/24	NF	ADDENDUM #3

ILLINOIS DESIGN FIRM # 184.001322  
1391 CORPORATE DRIVE, SUITE 203  
McHENRY, ILLINOIS 60050  
PHONE: 815.385.1778 | TOLL FREE: 800.728.7805  
FAX: 815.385.1781 | HRGreen.com

**EAST SERVICE AREA PHASE 1**  
**SANITARY SEWER EXTENSION**  
**VILLAGE OF JOHNSBURG**  
JOHNSBURG, ILLINOIS

FOR BID  
GRAVITY SEWER MAIN PLAN & PROFILE

SHEET NO.  
**CU103**

**FORCE MAIN – PLAN VIEW  
STA. 0+00 TO 5+00**

SCALE: 1" = 20'  
0 5 10 20

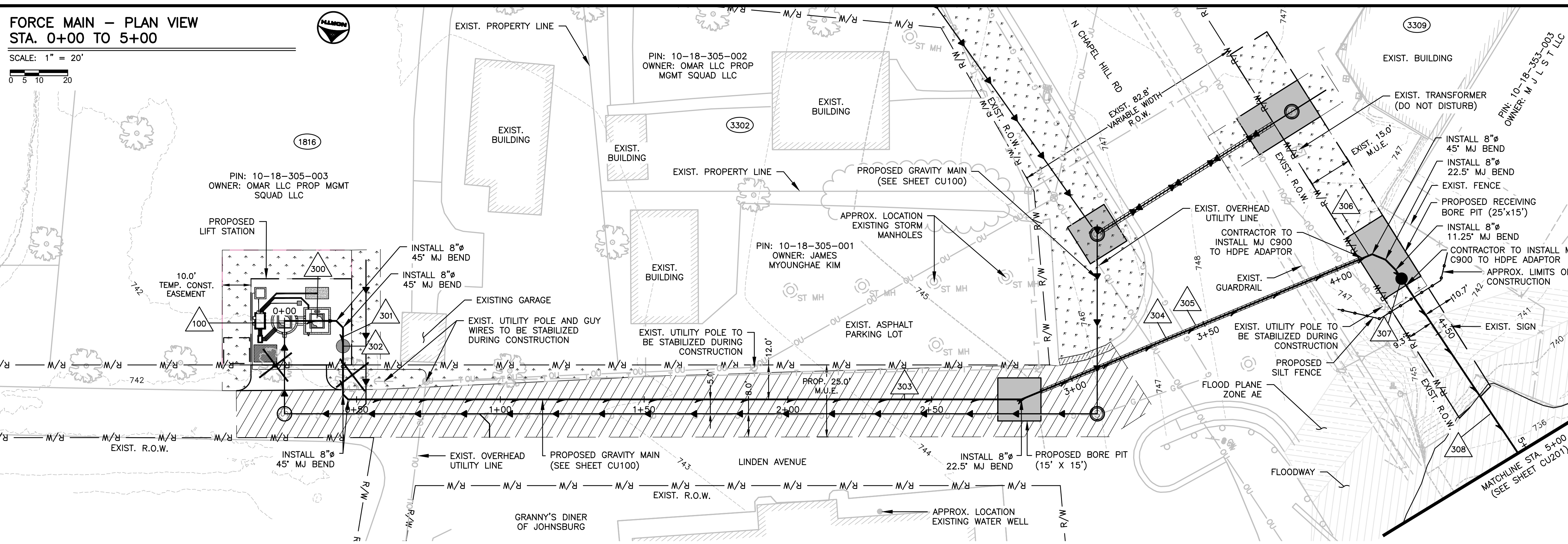

**SANITARY SEWER TAGS**

300	8" x 8" VALVE VAULT RIM: 742.50' INV. 4": 731.75'
301	8" AWWA C900 DR 18 PVC LENGTH: 12 L.F.
302	4" SAN. MANHOLE w/ ARV STA: 0+27.69 RIM: 742.00' INV. 4": 732.50'
303	8" AWWA C900 DR 18 PVC LENGTH: 254 L.F.
304	8" AWWA C900 DR 18 PVC LENGTH: 128 L.F.
305	18" STEEL ENCASUREMENT PIPE LENGTH: 120 L.F.
306	8" AWWA C900 DR 18 PVC LENGTH: 20 L.F.
307	4" VALVE VAULT w/ 8" GATE VALVE STA: 4+27.00 RIM: 744.00'
308	8" HDPE AWWA C906 PE4710 DR 11 (DIPS) LENGTH: 70 L.F.

**EASEMENT REFERENCE DOCUMENTS**

PIN: 10-18-353-003 DOC#: 2023R0009700
PIN: 10-18-305-003 DOC#: 2022R0038589
PIN: 10-18-355-001 DOC#: 2022R0038589

- BORING NOTES:**
- ALL BORES UNDER NORTH CHAPEL HILL ROAD SHALL BE CONSTRUCTED BY AUGER AND JACK METHOD.
  - CONTRACTOR SHALL USE APPROVED AND APPROPRIATE METHODS FOR CONTAINING SOIL AT BORING AND RECEIVING PITS.

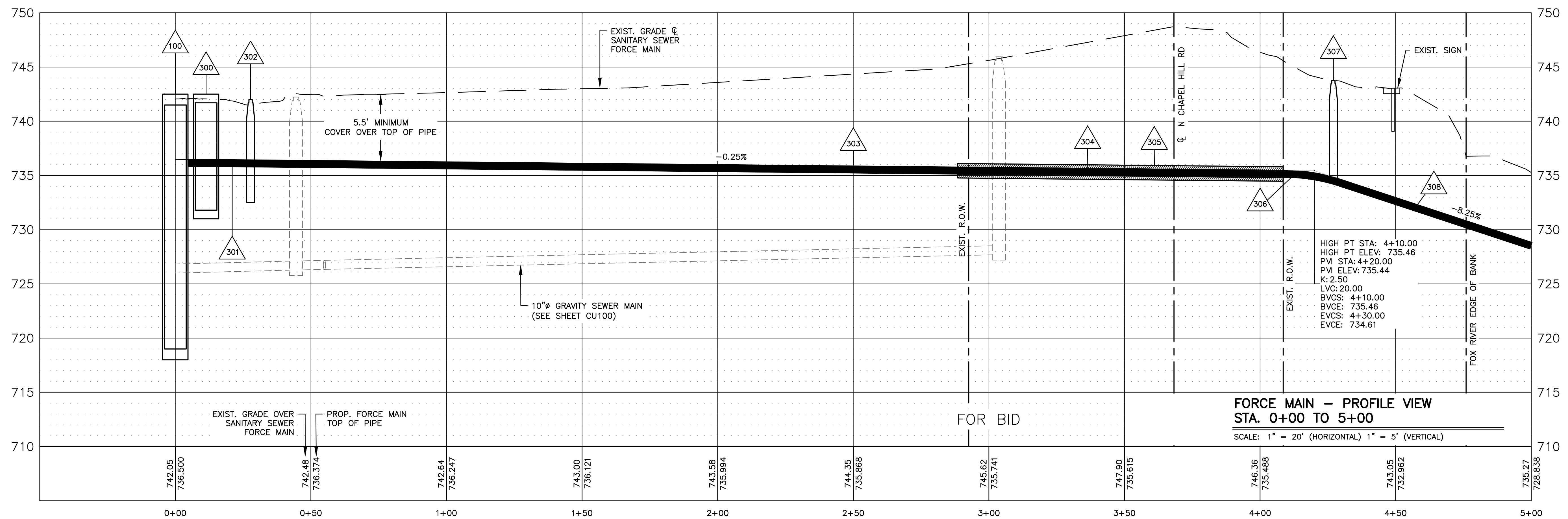

**FORCE MAIN – PROFILE VIEW  
STA. 0+00 TO 5+00**

SCALE: 1" = 20' (HORIZONTAL) 1" = 5' (VERTICAL)

DRAWN BY: HCM  
APPROVED: SGM  
CAD DATE: 1/9/2024 1:41:12 PM  
CAD FILE: \\hrgreen.com\HRG\Data\2021\210915\CAD\Drawings\210915\_CU200\_Force Main System.dwg

JOB DATE: 2022  
JOB NUMBER: 210915

BAR IS ONE INCH ON OFFICIAL DRAWINGS.  
IF NOT ONE INCH, ADJUST SCALE ACCORDINGLY.

NO.	DATE	BY	REVISION DESCRIPTION
1	1/5/24	NF	ADDENDUM #3

**HRGreen**  
ILLINOIS DESIGN FIRM # 184.001322  
1391 CORPORATE DRIVE, SUITE 203  
McHENRY, ILLINOIS 60050  
PHONE: 815.385.1778 | TOLL FREE: 800.728.7805  
FAX: 815.385.1781 | HRGreen.com

**EAST SERVICE AREA PHASE 1  
SANITARY SEWER EXTENSION  
VILLAGE OF JOHNSBURG  
JOHNSBURG, ILLINOIS**

FOR BID  
**FORCE MAIN PLAN & PROFILE**

SHEET NO.  
**CU200**

Xrefs: xref-1-dh01; 210915\_CU\_Fin; 210915\_CU\_LLS

**FORCE MAIN – PLAN VIEW  
STA. 5+00 TO 10+00**

SCALE: 1" = 20'  
0 5 10 20



**SANITARY SEWER TAGS**  
309 8" Ø HDPE AWWA C906 PE4710 DR 11 (DIPS)  
LENGTH: 500 L.F.

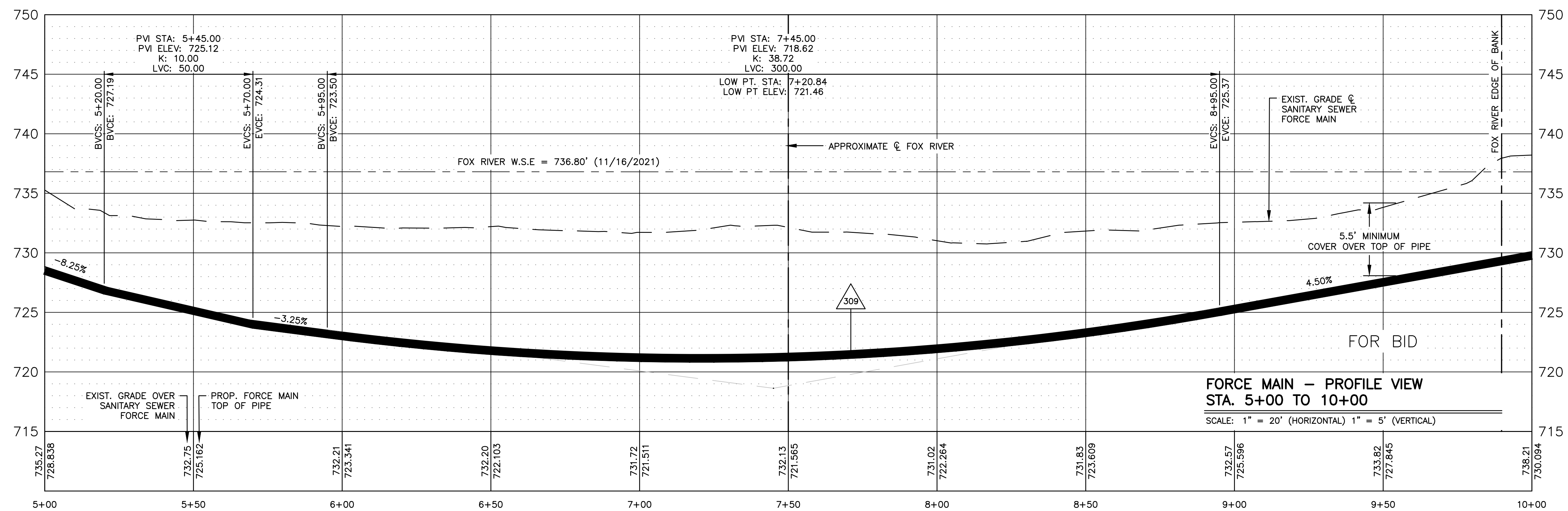
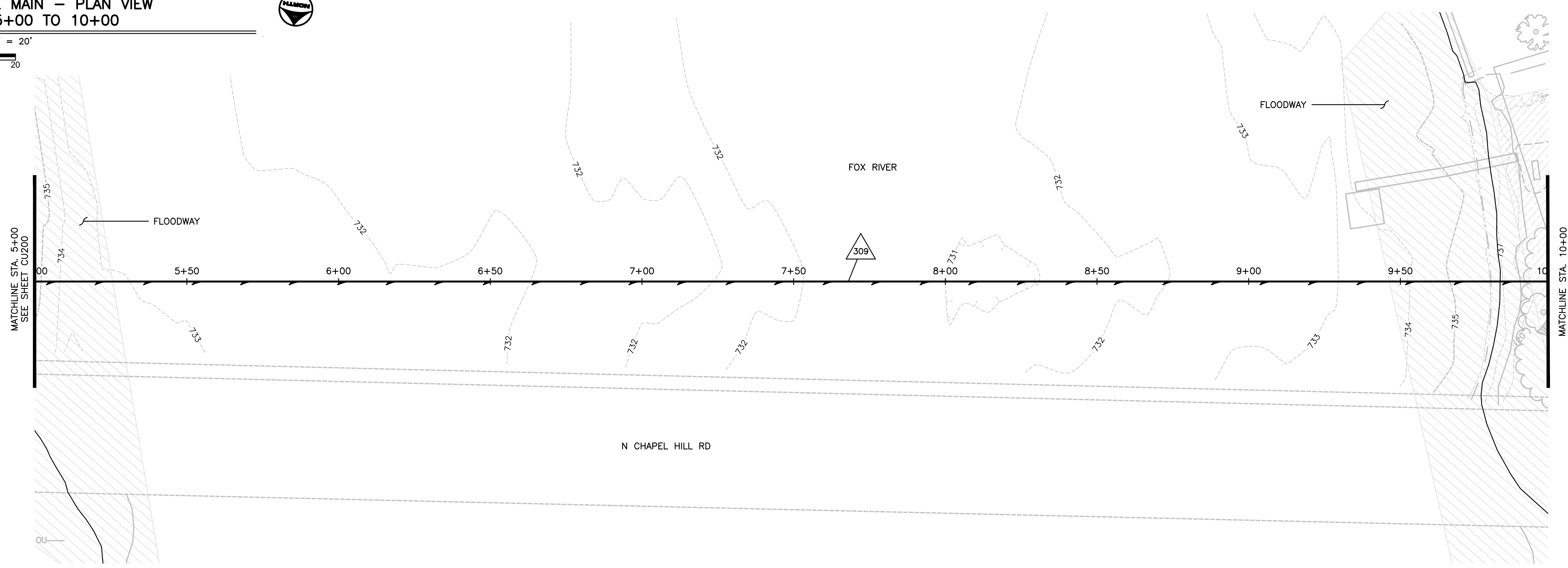

Xref: xref=1-dh01: 210915\_Survey; 210915\_CU\_FM; 210915\_CU\_LLS

DRAWN BY: HCM	JOB DATE: 2022	BAR IS ONE INCH ON OFFICIAL DRAWINGS: 0
APPROVED: SCM	JOB NUMBER: 210915	IF NOT ONE INCH, ADJUST SCALE ACCORDINGLY.
CAD DATE: 1/9/2024 1:41:12 PM		
CAD FILE: \\hrgreen.com\HRG\Data\2021\210915\CAD\Dwgs\C\210915_CU200_Force Main System.dwg		

NO.	DATE	BY	REVISION DESCRIPTION
1	1/5/24	NF	ADDENDUM #3

**HRGreen**  
ILLINOIS DESIGN FIRM # 184.001322  
1391 CORPORATE DRIVE, SUITE 203  
McHENRY, ILLINOIS 60050  
PHONE: 815.385.1778 | TOLL FREE: 800.728.7805  
FAX: 815.385.1781 | HRGreen.com

**EAST SERVICE AREA PHASE 1  
SANITARY SEWER EXTENSION  
VILLAGE OF JOHNSBURG  
JOHNSBURG, ILLINOIS**

FOR BID  
**FORCE MAIN PLAN & PROFILE**

SHEET NO.  
**CU201**

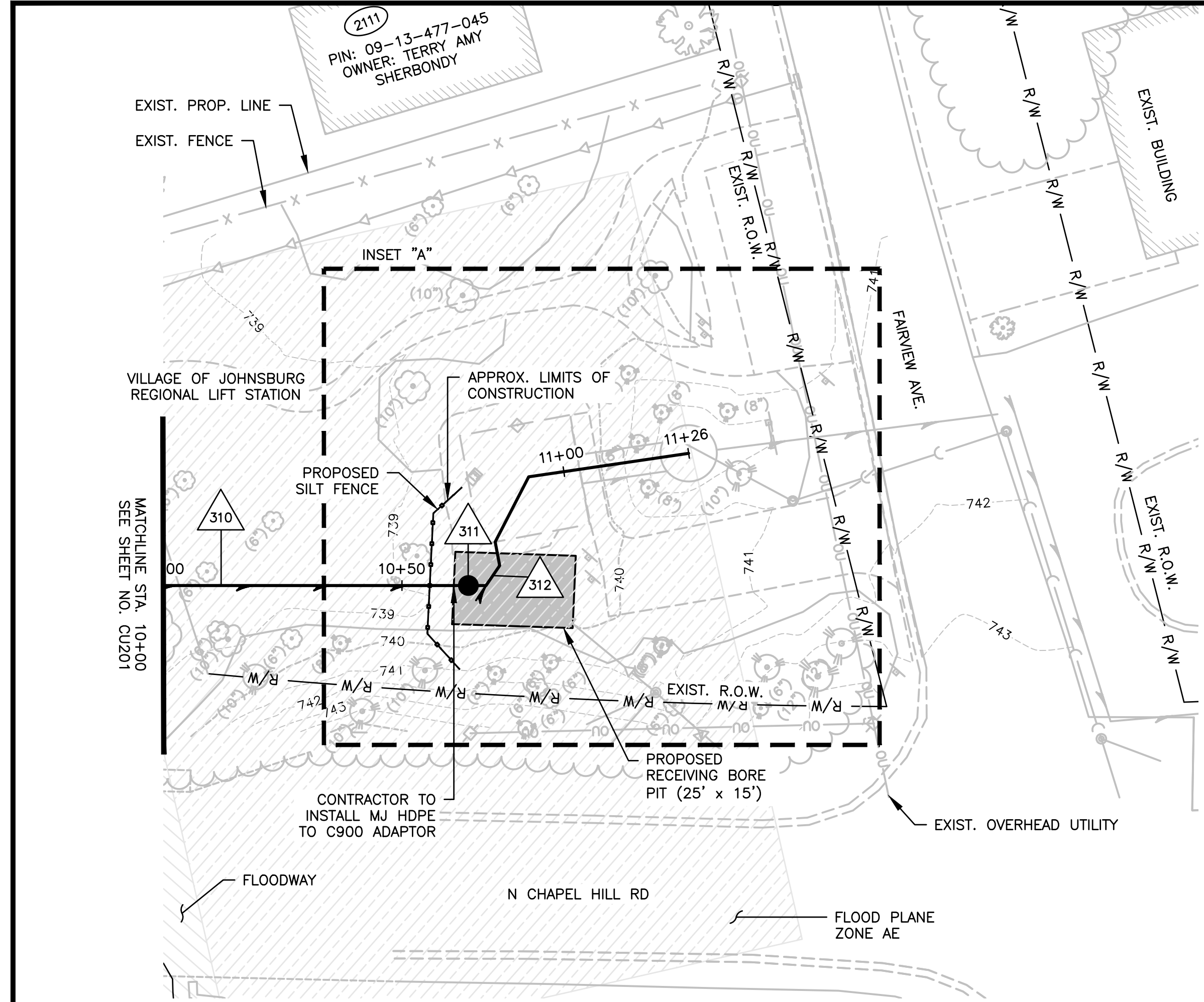

**FORCE MAIN – PLAN VIEW  
STA. 10+00 TO STA. 11+50**

SCALE: 1" = 20'  
0 5 10 20

#	SANITARY SEWER TAGS
310	8" Ø HDPE AWWA C906 PE4710 DR 11 (DIP) LENGTH: 62 L.F.
311	4" Ø VALVE VAULT w/8" Ø GATE VALVE STA: 10+64.00 RIM: 739.25'
312	8" Ø AWWA C900 DR 18 PVC LENGTH: 18 L.F. SLOPE: 4.00%

**BORING NOTES:**

- CONTRACTOR SHALL USE APPROVED AND APPROPRIATE METHODS FOR CONTAINING SOIL AT BORING AND RECEIVING PITS.

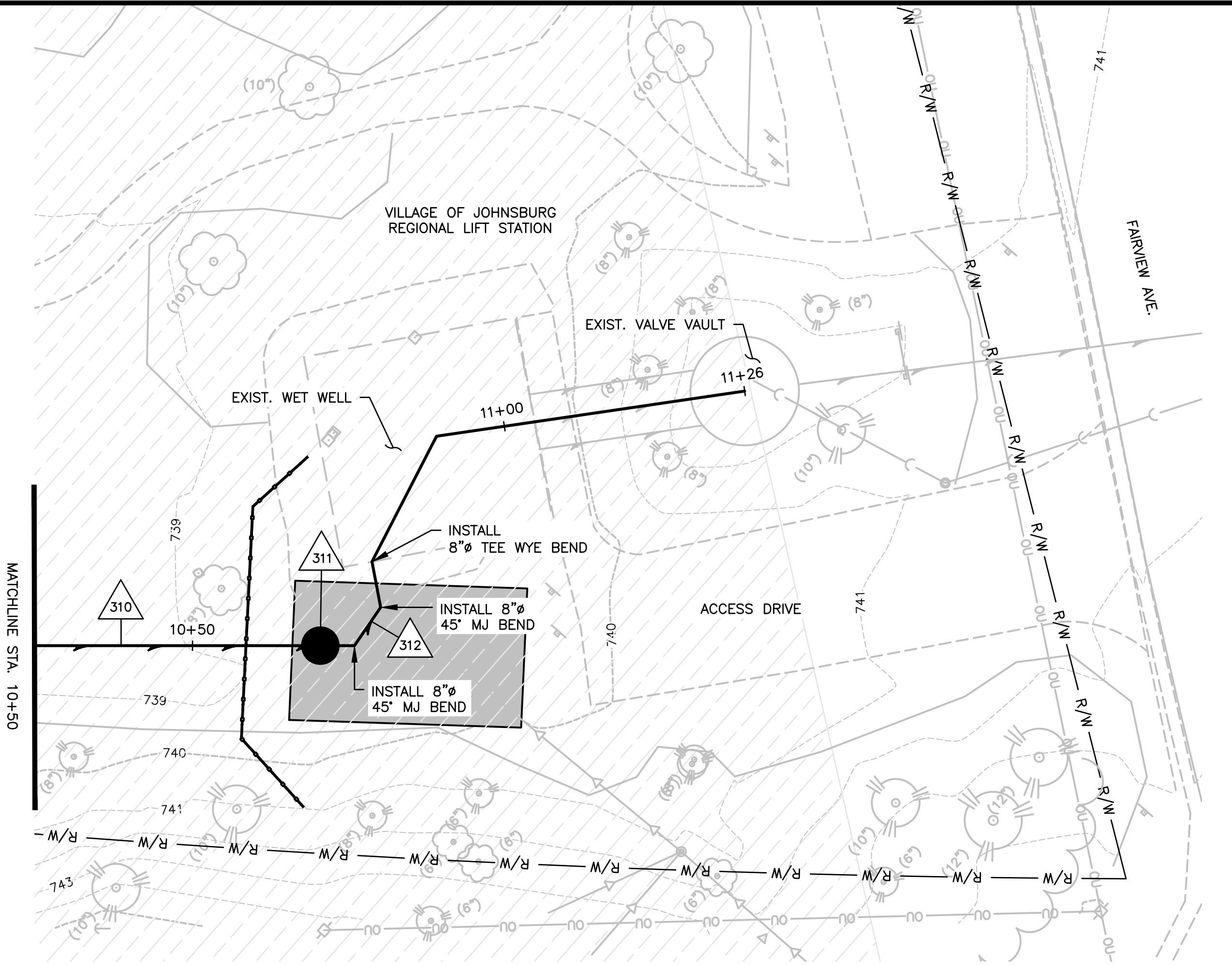

**INSET "A"**

SCALE: 1" = 10'  
0 5 10

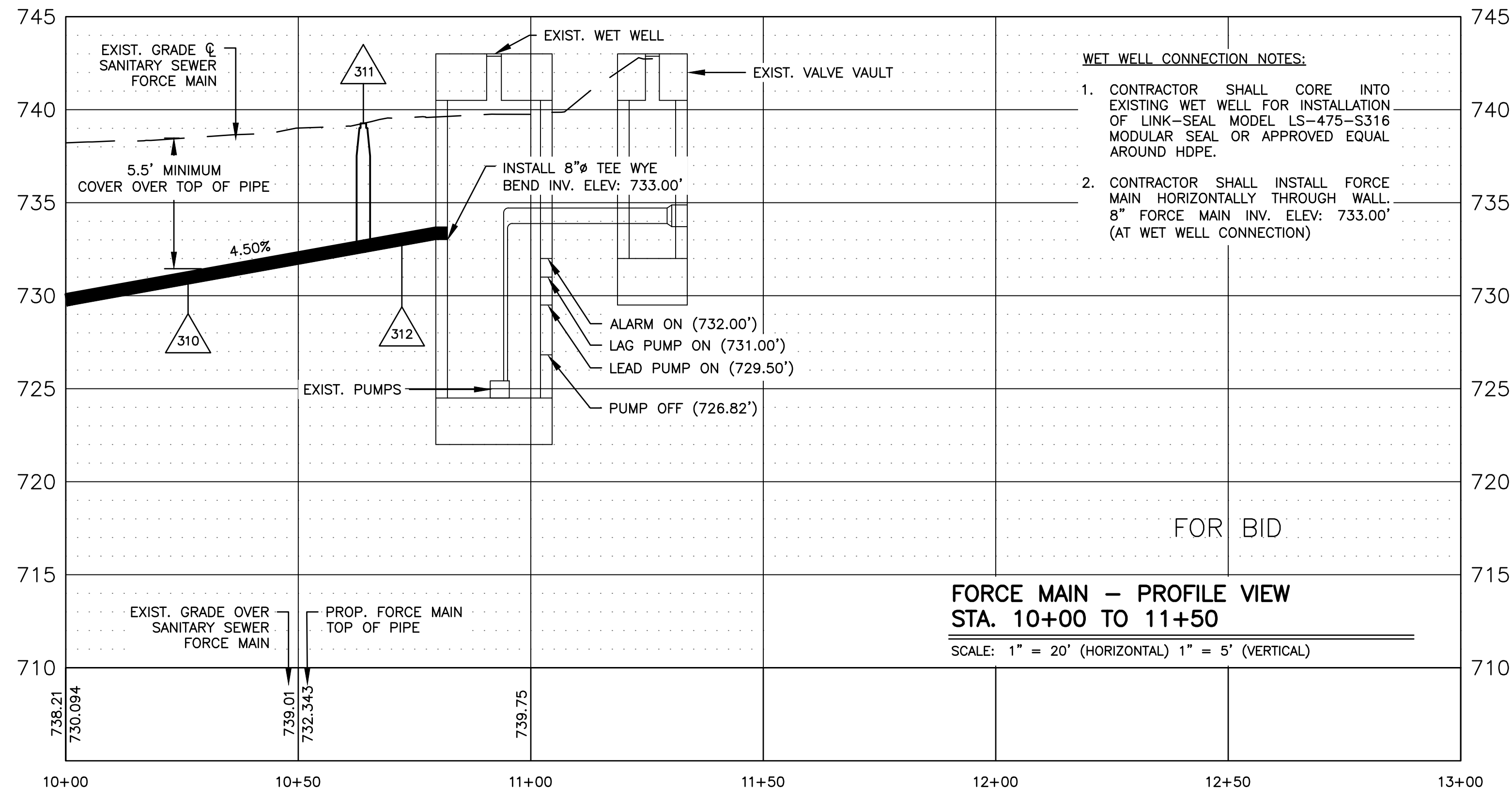

- WET WELL CONNECTION NOTES:**
- CONTRACTOR SHALL CORE INTO EXISTING WET WELL FOR INSTALLATION OF LINK-SEAL MODEL LS-475-S316 MODULAR SEAL OR APPROVED EQUAL AROUND HDPE.
  - CONTRACTOR SHALL INSTALL FORCE MAIN HORIZONTALLY THROUGH WALL. 8" FORCE MAIN INV. ELEV: 733.00' (AT WET WELL CONNECTION)

FOR BID

**FORCE MAIN – PROFILE VIEW  
STA. 10+00 TO 11+50**

SCALE: 1" = 20' (HORIZONTAL) 1" = 5' (VERTICAL)

Xref: xref-1-dh01: 210915\_Survey; 210915\_CU\_FM; 210915\_CU\_LLS

DRAWN BY: HCM	JOB DATE: 2022	BAR IS ONE INCH ON OFFICIAL DRAWINGS:
APPROVED: SGM	JOB NUMBER: 210915	0
CAD DATE: 1/9/2024 1:41:12 PM		IF NOT ONE INCH, ADJUST SCALE ACCORDINGLY.
CAD FILE: \\hrgreen.com\HRG\Data\2021\210915\CAD\Dwgs\C\210915_CU200_Force Main System.dwg		

NO.	DATE	BY	REVISION DESCRIPTION
1	1/5/24	NF	ADDENDUM #3

**HRGreen**  
ILLINOIS DESIGN FIRM # 184.001322  
1391 CORPORATE DRIVE, SUITE 203  
McHENRY, ILLINOIS 60050  
PHONE: 815.385.1778 | TOLL FREE: 800.728.7805  
FAX: 815.385.1781 | HRGreen.com

**EAST SERVICE AREA PHASE 1  
SANITARY SEWER EXTENSION  
VILLAGE OF JOHNSBURG  
JOHNSBURG, ILLINOIS**

FOR BID  
**FORCE MAIN PLAN & PROFILE**

SHEET NO.  
**CU202**

**SANITARY SEWER TAGS**

- 100\* 8" Ø WET WELL  
RM: 742.50'  
INV. 10"Ø: 726.00'
- 101\* 10" Ø ASTM D3034 SDR26 PVC  
LENGTH: 29 L.F.  
SLOPE: 1.00%
- 102 4" Ø SAN. MANHOLE  
STA.: 0+32.33  
RM: 742.23'  
INV. 10"Ø: 726.28' (W)  
INV. 10"Ø: 726.28' (S)
- 103 6" Ø ASTM D3034 SDR26  
LENGTH: 50 L.F.  
SLOPE: 1.00%
- 104 6" Ø ASTM D3034 SDR26  
LENGTH: 10 L.F.  
SLOPE: 10.00%
- 105 10" Ø AWWA C900 DR18 PVC  
LENGTH: 283 L.F.  
SLOPE: 0.50%
- 117\* 4" Ø ASTM D3034 SDR26 PVC  
LENGTH: 15 L.F.  
SLOPE: 5.00%
- 300\* 8'x8' VALVE VAULT  
RM: 742.50'  
INV. 4"Ø: 731.75'
- 301\* 8" Ø AWWA C900 DR 18 PVC  
LENGTH: 12 L.F.
- 302\* 4" Ø SAN. MANHOLE w/ARV  
STA: 0+27.69  
RM: 742.00'  
INV. 4"Ø: 732.50'
- 303 8" Ø AWWA C900 DR 18 PVC  
LENGTH: 254 L.F.
- \* ITEM INCLUDED IN LIFT STATION LUMP SUM BID ITEM

**SEWER TAG #302 NOTES:**

1. CONTRACTOR SHALL PROVIDE CORED OR CAST HOLES (1 REQ.) BY PRECAST MANUFACTURER - FOR INSTALLATION OF LINK-SEAL MODEL LS-315-S316 MODULAR SEALS OR APPROVED EQUAL AROUND 4" Ø ARV VAULT DRAIN
2. CONTRACTOR SHALL PROVIDE CORED OR CAST HOLES (2 REQ.) BY PRECAST MANUFACTURER - FOR INSTALLATION OF LINK-SEAL MODEL LS-400-S316 MODULAR SEALS OR APPROVED EQUAL AROUND 8" PVC FORCE MAIN.

**LEGEND:**

- DENOTES HEAVY DUTY PAVEMENT SECTION
- DENOTES PROPOSED HMA PAVEMENT REMOVAL AND REPLACEMENT (CLASS D PATCHING) (FULL DEPTH)
- DENOTES TEMPORARY CONCRETE WASHOUT AREA
- DENOTES GRASS RESTORATION AREA
- DENOTES EROSION CONTROL FENCE (SEE DETAILS.)
- DENOTES PROPOSED DRAINAGE DIRECTION ARROW.
- DENOTES PROPOSED OVERFLOW DIRECTION ARROW.
- DENOTES EXISTING AND OR PROPOSED SPOT ELEVATIONS.

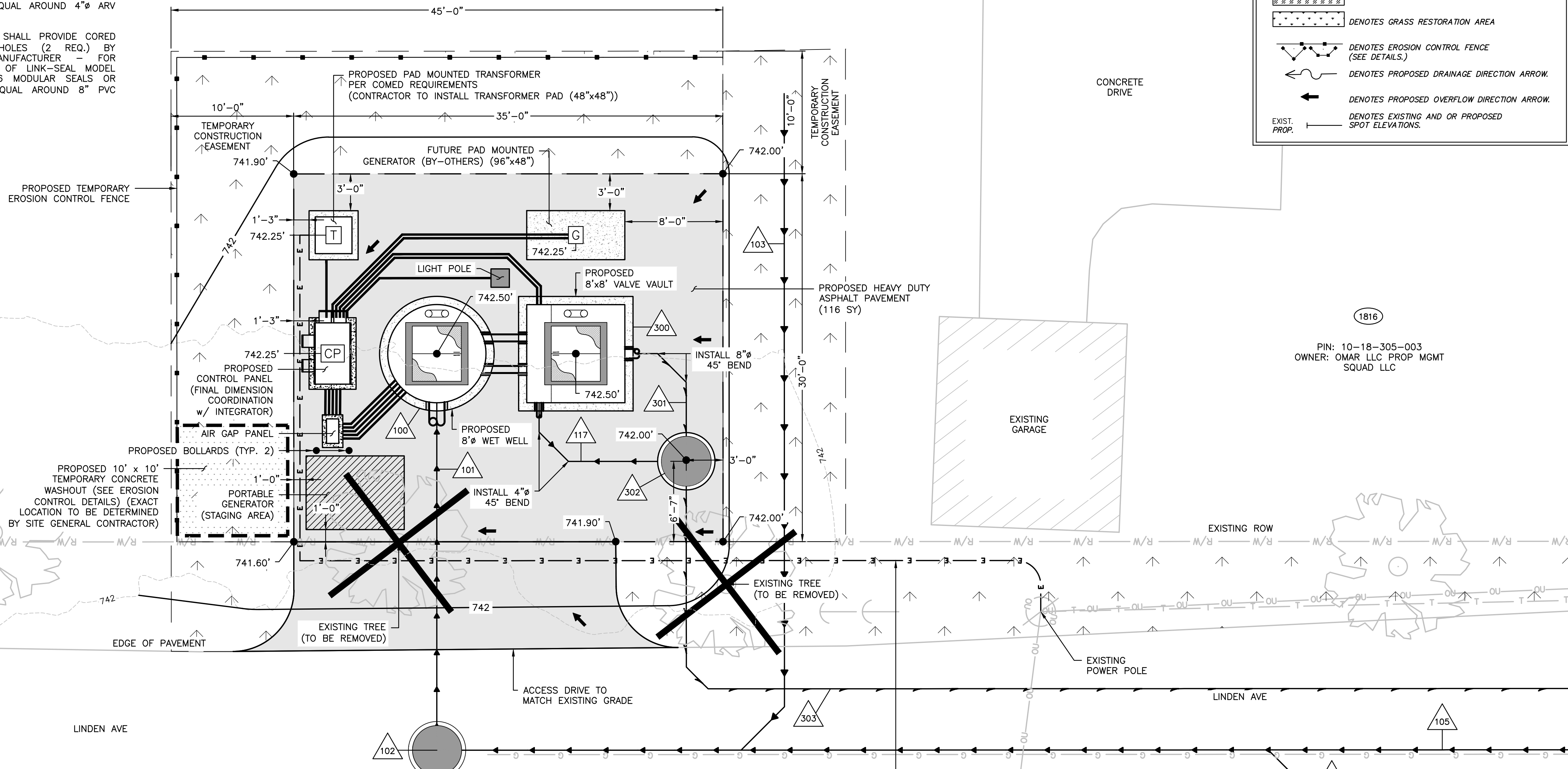

1816  
PIN: 10-18-305-003  
OWNER: OMAR LLC PROP MGMT SQUAD LLC

**EASEMENT REFERENCE DOCUMENTS**

- PIN: 10-18-353-003  
DOC#: 2023R0009700
- PIN: 10-18-305-003  
DOC#: 2022R0038589
- PIN: 10-18-355-001  
DOC#: 2022R0038589

**GRADING AND DRAINAGE NOTES:**

- ALL SEDIMENTATION AND EROSION CONTROL REGULATIONS SHALL BE ADHERED TO PER VILLAGE OF JOHNSBURG'S REQUIREMENTS
- SITE GRADING SHALL NOT PROCEED UNTIL EROSION CONTROL MEASURES HAVE BEEN INSTALLED.
- NO DIMENSIONS SHALL BE ASSUMED BY SCALING.
- NO PART OF THE PROPOSED PROJECT IS LOCATED WITHIN A FLOOD HAZARD 10-100YR AREA.
- NO KNOWN DRAIN TILES ARE PRESENT ON THE PROPOSED DEVELOPMENT, IF TILES ARE ENCOUNTERED DURING CONSTRUCTION PLEASE NOTIFY THE ENGINEER IMMEDIATELY.
- ALL TOPSOIL SHALL BE STRIPPED PRIOR TO FILLING
- SILT FILTER BASKETS SHALL BE PLACED BETWEEN FRAME AND GRATE UNTIL VEGETATION IS ESTABLISHED.
- ALL EXISTING STRUCTURES & DEBRIS NOTED TO BE REMOVED, SHALL BE REMOVED PRIOR TO CONSTRUCTION & DISPOSED OF OFFSITE. NO ON SITE BURNING WILL BE ALLOWED
- SPOT ELEVATIONS SHOWN ARE @ EDGE OF PAVEMENT UNLESS OTHERWISE NOTED ON PLAN.
- GROUND COVER FOR 3:1, 4:1, & 5:1 SLOPES SHALL BE ESTABLISHED WITHIN SEVEN DAYS OF FINAL GRADING.
- ALL DISTURBED AREAS TO TO RESTORED W/ 6" TOPSOIL RESPIRAD & SEEDING/SODDING UNLESS OTHERWISE NOTED ON PLANS.  
\*SEEDING PER I.D.O.T. MANUAL, SECTION 251, STANDARD SPECIFICATIONS FOR ROAD AND BRIDGE CONSTRUCTION, (LATEST EDITION)  
\*CLASS 1A SALT TOLERANT LAWN MIXTURE  
\*MULCH/HYDROSEED PER I.D.O.T. MANUAL, SECTION 251, STANDARD SPECIFICATIONS FOR ROAD AND BRIDGE CONSTRUCTION, (LATEST EDITION)  
\*MULCH/HYDROSEED METHOD 2, PROCEDURE 3
- EXCESS MATERIAL SHALL BE DISPOSED OF OFFSITE AT AN APPROVED LAND FILL. CONTRACTOR TO LEAVE ENOUGH MATERIAL ONSITE TO ESTABLISH PROP. GRADES FOR SEED/MULCH. ANY STOCKPILES LEFT ONSITE FOR THIS PURPOSE SHALL BE SURROUNDED BY FILTER FENCE AND SHALL BE SEEDED PER I.D.O.T. MANUAL (LATEST ADDITION) (TEMPORARY) IF LEFT MORE THAN 14 DAYS.

**PROJECT NOTES:**

- ALL PAVEMENT DIMENSIONS ARE MEASURED TO THE EDGE OF PAVEMENT UNLESS OTHERWISE NOTED.
- ALL PAVEMENT RADII ARE MEASURED TO THE EDGE OF PAVEMENT UNLESS OTHERWISE NOTED.
- ALL EXISTING UTILITIES TO BE FIELD VERIFIED PRIOR TO CONSTRUCTION.
- LOCATION OF PROPOSED SITE UTILITIES SHALL BE VERIFIED BY GENERAL CONTRACTOR AND THE APPROPRIATE UTILITY COMPANY PROVIDING SERVICE.
- ELECTRICAL SERVICE TO POLE MOUNTED TRANSFORMER OR ONSITE GROUND MOUNTED TRANSFORMER SHALL BE RUN UNDERGROUND, COORDINATION BY GENERAL CONTRACTOR.
- ALL TRENCHING, PIPE LAYING, AND BACKFILLING SHALL BE IN ACCORDANCE WITH FEDERAL OSHA REGULATIONS.
- GENERAL CONTRACTOR SHALL HAVE APPROVAL OF ALL GOVERNING AGENCIES HAVING JURISDICTION OVER THIS SYSTEM PRIOR TO INSTALLATION.
- ALL UTILITIES ARE APPROXIMATE LOCATIONS PROVIDED BY UTILITY COMPANIES ATLAS MAPS.
- ALL UTILITIES ARE TO BE LOCATED BY J.U.L.I.E. PRIOR TO CONSTRUCTION.
- MAINTAIN 18" VERTICAL SEPARATION BETWEEN WATER AND SEWER (PER I.E.P.A. STANDARDS)
- MAINTAIN 10' HORIZONTAL SEPARATION BETWEEN WATER AND SEWER (PER I.E.P.A. STANDARDS)
- SEE SITE SPECIFICATIONS FOR BACKFILLING AND COMPACTION REQUIREMENTS.
- SANITARY FORCEMAIN DEPTH IS A MINIMUM OF 5.5' TO THE TOP OF PIPE UNLESS OTHERWISE NOTED ON PLANS.
- REMOVE EXIST. TREES AND BRUSH AS NECESSARY FOR CONSTRUCTION.
- ALL FITTINGS FOR THE SANITARY FORCE MAIN SHALL HAVE RESTRAINT JOINT FITTINGS AT EACH JOINT (MEG-A-LUGS)
- CONTRACTOR TO INSTALL APPROVED PIPE COUPLINGS OR FITTINGS SUITABLE TO ADAPT FROM D.I.P. TO OTHER PIPE MATERIALS, IF NECESSARY
- COORDINATE ONE LANE CLOSURE AS NEEDED FOR CONSTRUCTION



**LIFT STATION - SITE PLAN**

SCALE: 1" = 5'

FOR BID

Xrefs: xgt-1-dm01; 210915\_CU300; 210915\_Survey

DRAWN BY: HCM      JOB DATE: 2022  
 APPROVED: SGM      JOB NUMBER: 210915  
 CAD DATE: 1/9/2024 10:38:34 AM  
 CAD FILE: J:\2021\210915\CAD\DWG\C\210915\_CU300\_Lift Station Site Plan.dwg

NO.	DATE	BY	REVISION DESCRIPTION
1	1/5/24	NF	ADDENDUM #3

ILLINOIS DESIGN FIRM # 184.001322  
 1391 CORPORATE DRIVE, SUITE 203  
 McHENRY, ILLINOIS 60050  
 PHONE: 815.385.1778 | TOLL FREE: 800.728.7805  
 FAX: 815.385.1781 | HRGreen.com

**EAST SERVICE AREA PHASE 1  
 SANITARY SEWER EXTENSION  
 VILLAGE OF JOHNSBURG  
 JOHNSBURG, ILLINOIS**

FOR BID  
**LIFT STATION - SITE PLAN**

SHEET NO.  
**CU300**

LIFT STATION GENERAL NOTES:

- LIFT STATION SHALL BE INSTALLED BY AN EXPERIENCED AND QUALIFIED CONTRACTOR.
- LIFT STATION SHALL BE DUPLEX WITH SUBMERSIBLE NON CLOG PUMPS WITH 316 STAINLESS STEEL GUIDE RAIL SYSTEM AND BREAKAWAY FITTINGS.
- CONTRACTOR SHALL VERIFY ALL DIMENSIONS, ELEVATIONS, PIPING LAYOUTS AND ORIENTATION OF INLET(S), DISCHARGE AND CONDUIT(S).
- STAINLESS STEEL SHALL BE 304 OR 316 UNLESS SPECIFIED OTHERWISE.
- ALL INTERNAL HARDWARE, BRACKETS, FABRICATIONS, ETC. SHALL BE 304 OR 316 STAINLESS STEEL.
- CONTRACTOR SHALL SUBMIT ALL SHOP DRAWINGS OF WET WELL, VALVE VAULT, AND PIPING, VALVES AND ALL MECHANICAL EQUIPMENT TO ENGINEER FOR REVIEW AND APPROVAL.

SUBMERSIBLE PUMP GENERAL NOTES:

- THE FLOOR OF THE WET WELL SHALL BE FORMED PER PUMP MANUFACTURER'S RECOMMENDATION.
- PUMPS SHALL BE LOCATED AND ANCHORED PER MANUFACTURER'S RECOMMENDATION.
- CONTRACTOR SHALL COORDINATE WITH THE PUMP MANUFACTURER FOR THE DIMENSION, AND LOCATION OF ALL ACCESS DOORS.
- PUMPS SHALL BE EXPLOSION-PROOF RATED AND INTRINSICALLY-SAFE BARRIERS SHALL BE UTILIZED FOR CLASS 1, DIVISION 1, GROUP D LOCATIONS.

PUMP DESIGN

PUMP CAPACITY: 325 GPM TDH: 20.67 FT

PIPING GENERAL NOTES:

- ALL PIPING AND VALVES SHALL BE PROVIDED BY THE CONTRACTOR UNLESS NOTED OTHERWISE.
- ALL INTERIOR PIPE SHALL BE PAINTED PER TECHNICAL SPECIFICATION.
- ALL PIPING AS SHOWN SHALL BE DUCTILE IRON PIPE CLASS 52, AND BE CEMENT-MORTAR LINED.
- BOLTS AND NUTS SHALL CONFORM TO ASTM A316 STAINLESS STEEL.
- ALL PIPE PENETRATIONS TO THE WET WELL AND VALVE VAULT SHALL BE SEALED USING LINK-SEAL OR APPROVED EQUAL.
- ALL FITTINGS INSIDE THE WET WELL SHALL BE FLANGED.
- ALL FITTINGS AND VALVES SHALL BE 250 PSI WORKING PRESSURE MINIMUM.
- ALL VALVES SHALL BE RATED FOR SEWER SERVICE.
- ALL VALVES SHALL BE F.B.E. COATED INTERIOR AND EXTERIOR.

WET WELL AND VALVE VAULT GENERAL NOTES:

- REINFORCE CONCRETE STRUCTURE SHALL BE ASTM C-478 C-WALL THICKNESS WITH O-RING COMPRESSIVE JOINTS, TYPE II CEMENT.
- ALL REINFORCED STEEL SHALL CONFORM TO ASTM A-615, GRADE 60.
- ALL GROUT SHALL BE NON-SHRINK, HAVING MINIMUM COMPRESSIVE STRENGTH OF 5,000 PSI AT 28 DAYS, COMPLYING WITH ASTM C-1107.
- ALL PIPE OPENINGS SHALL BE SUFFICIENT SIZE CORED FOR LINK-SEAL MODEL LS-360-S316 MODULAR SEALS OR APPROVED EQUAL.
- THE FOUNDATION OF THE WET WELL SHALL REST UN UNDISTURBED SOIL.
- INSTALL FLOAT SWITCHES AWAY FROM THE INFLUENT PIPE TO AVOID TURBULENCE.
- ALL INTERNAL SURFACES OF THE WET WELL SHALL BE COATED WITH OBIC, MULTI-COMPONENT, STRESS SKIN PANEL LINER SYSTEM, OR ENGINEER APPROVED EQUIVALENT.
- THE EXTERIOR OF THE WET WELL SHALL BE COATED WITH COAL TAR EPOXY ACCORDING TO MANUFACTURER'S RECOMMENDATION FOR USE ON WET WELLS.
- THE EXTERNAL JOINTS OF THE PRECAST CONCRETE PIPE SECTIONS SHALL BE MAC-WRAP OR APPROVED EQUAL.

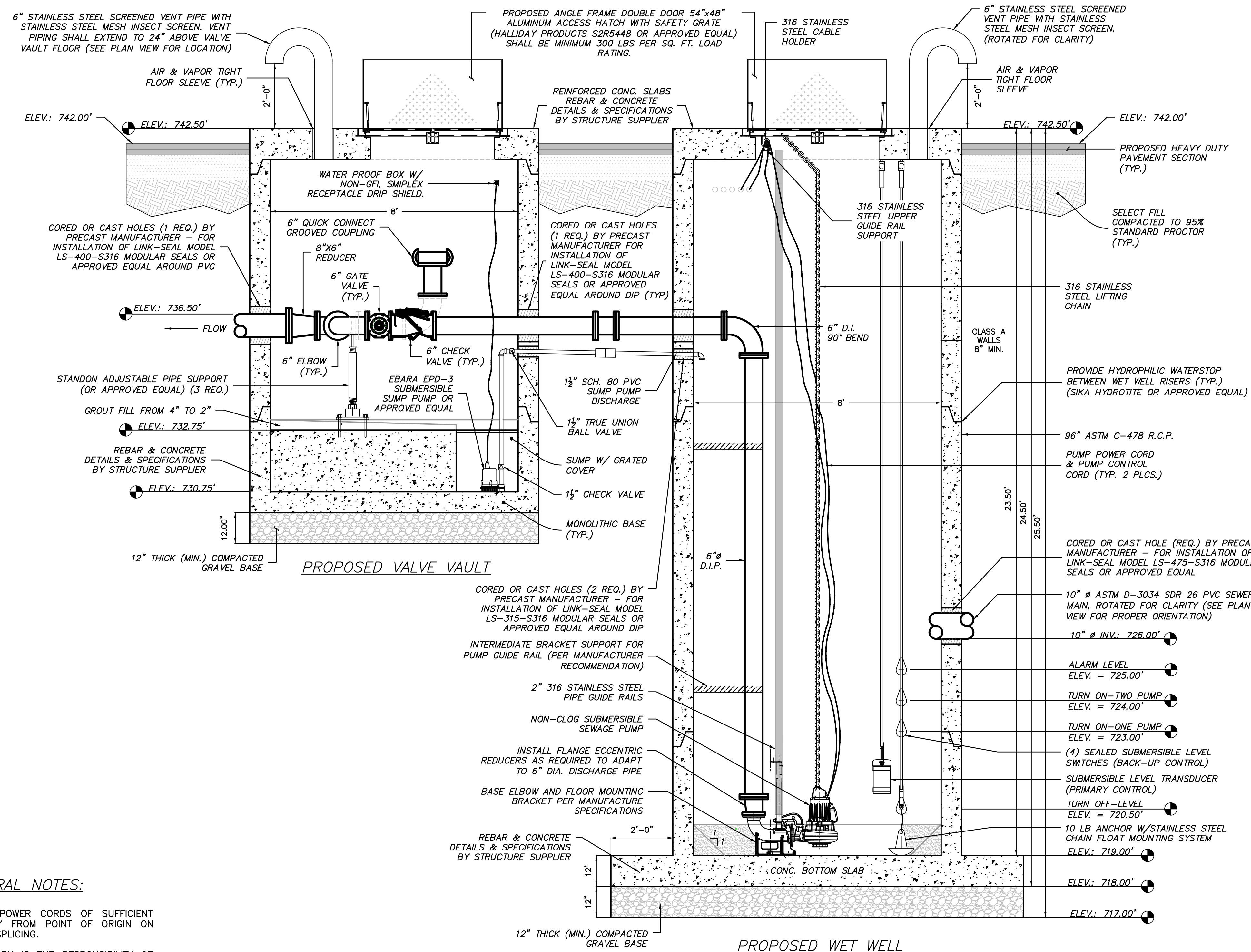

PROPOSED WET WELL  
PROPOSED VALVE VAULT  
WET WELL AND VALVE VAULT  
ELEVATION VIEW  
SCALE: N.T.S.

ELECTRICAL GENERAL NOTES:

- CONTRACTOR TO ORDER CONTROL & POWER CORDS OF SUFFICIENT LENGTHS TO REACH HAZARDOUS ENTRY FROM POINT OF ORIGIN ON PUMPS AND LEVEL CONTROLS WITHOUT SPLICING.
- ALL CONCRETE WORK AND CONDUIT WORK IS THE RESPONSIBILITY OF THE CONTRACTOR.
- ALL ELECTRICAL EQUIPMENT IN THE WET WELL SHALL CONFORM TO NEC REQUIREMENT FOR CLASS 1, DIVISION 1, GROUP D HAZARDOUS AREA.
- 5' OF PVC SECURED INTO TOP OF TRANSDUCER TO MIN. 2' ABOVE INVERT TO PROTECT TRANSDUCER WIRING
- HOUR METER FOR FUTURE GENERATOR TO BE PROVIDED IN CONTROL PANEL.

FOR BID

DRAWN BY: HCM JOB DATE: 2022  
APPROVED: SGM JOB NUMBER: 210915  
CAD DATE: 1/9/2024 1:25:24 PM  
CAD FILE: \\hrgreen.com\HRG\Data\2021\210915\CAD\DWG\C\210915\_CU300\_Lift Station System and Details.dwg

BAR IS ONE INCH ON OFFICIAL DRAWINGS.  
IF NOT ONE INCH, ADJUST SCALE ACCORDINGLY.

NO.	DATE	BY	REVISION DESCRIPTION

ILLINOIS DESIGN FIRM # 184.001322  
1391 CORPORATE DRIVE, SUITE 203  
McHENRY, ILLINOIS 60050  
PHONE: 815.385.1778 | TOLL FREE: 800.728.7805  
FAX: 815.385.1781 | HRGreen.com

**EAST SERVICE AREA PHASE 1**  
**SANITARY SEWER EXTENSION**  
**VILLAGE OF JOHNSBURG**  
JOHNSBURG, ILLINOIS

FOR BID  
**LIFT STATION - TYPICAL SECTION**

SHEET NO.  
**CU301**

Xrefs: xgt-1-dh01: 210915\_CU.LIS

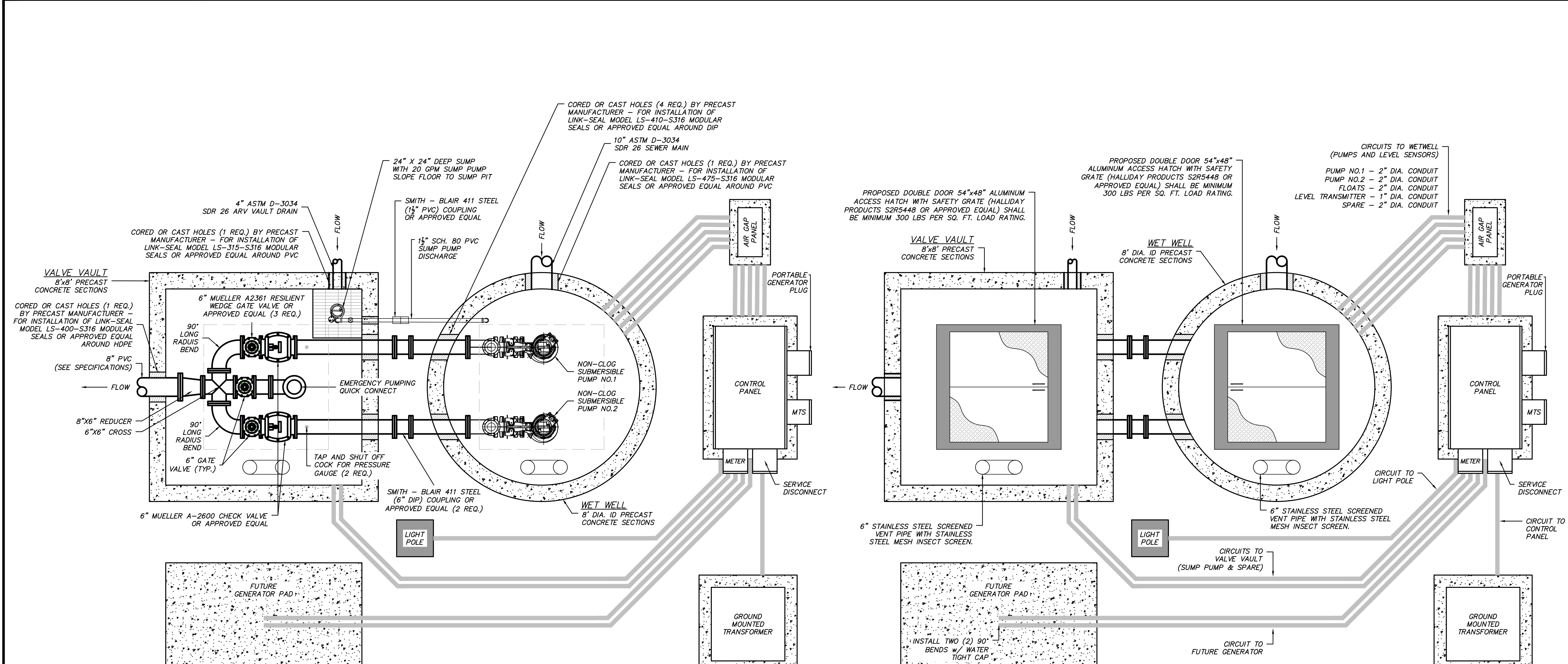

**PROPOSED  
VALVE VAULT & WET WELL  
PLAN VIEW  
SCALE: 1/2" = 1'**

**PROPOSED  
VALVE VAULT & WET WELL  
HATCH DETAIL  
SCALE: 1/2" = 1'**

**LIGHT POLE GENERAL NOTES:**

1. PROVIDE A LIGHT POLE AND LED FIXTURE. (FIELD VERIFY FINAL LOCATION)
2. POLE: DIRECT BURY 3" GALVANIZED HEAVY WALL STEEL WITH THREADED TOP CAP, MINIMUM 5' BURY DEPTH AND 15' ABOVE GRADE.
3. FIXTURE: STONCO MODEL ECF-S-32L-365-NW-G2-AR-4-UNV-FAWS-MGY OR ENGINEER APPROVED EQUIVALENT.
4. PROVIDE BREAKER FOR LIGHT FIXTURE IN CONTROL ENCLOSURE. PROVIDE WEATHERPROOF SWITCH AND COVER MOUNTED ON THE POLE.

NOTE: CONTRACTOR SHALL COORDINATE METER, SERVICE DISCONNECT, MTS, PORTABLE GENERATOR PLUG AND TRANSFORMER WITH VILLAGE'S INTEGRATION PROVIDER, ENGINEER AND COMED PRIOR TO CONSTRUCTING.

FOR BID

DRAWN BY: HCM	JOB DATE: 2022	BAR IS ONE INCH ON OFFICIAL DRAWINGS.
APPROVED: SGM	JOB NUMBER: 210915	0
CAD DATE: 1/9/2024 1:25:24 PM		IF NOT ONE INCH, ADJUST SCALE ACCORDINGLY.
CAD FILE: \\hrgreen.com\HRG\Data\2021\210915\CAD\Dwggs\C\210915_CU300_Lift Station System and Details.dwg		

NO.	DATE	BY	REVISION DESCRIPTION

**HRGreen**  
ILLINOIS DESIGN FIRM # 184.001322  
1391 CORPORATE DRIVE, SUITE 203  
McHENRY, ILLINOIS 60050  
PHONE: 815.385.1778 | TOLL FREE: 800.728.7805  
FAX: 815.385.1781 | HRGreen.com

**EAST SERVICE AREA PHASE 1  
SANITARY SEWER EXTENSION  
VILLAGE OF JOHNSBURG  
JOHNSBURG, ILLINOIS**

FOR BID  
**LIFT STATION - DETAILS**

SHEET NO.  
**CU302**

Xref: xgl-1-dh01: 210915\_CU302



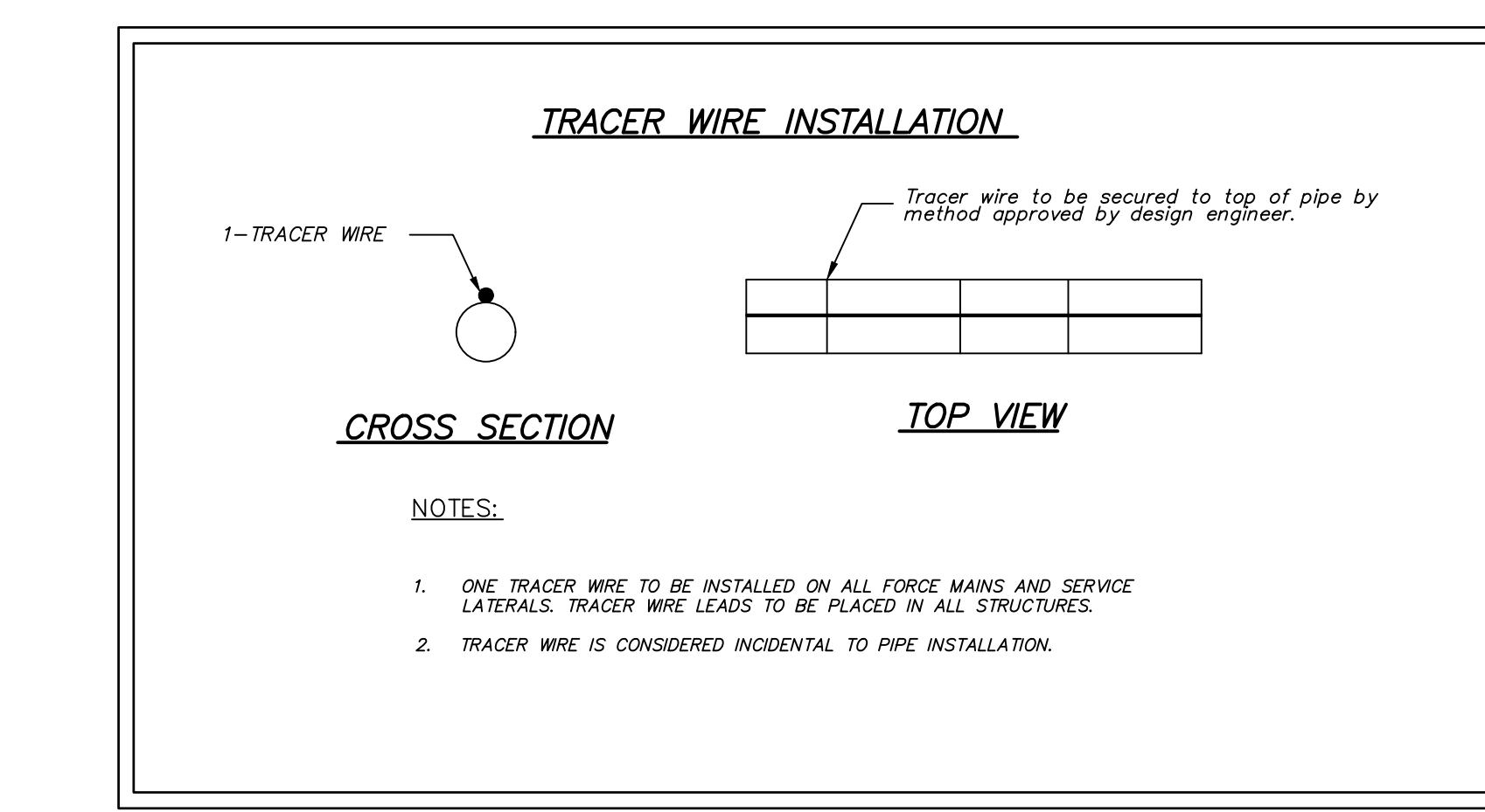
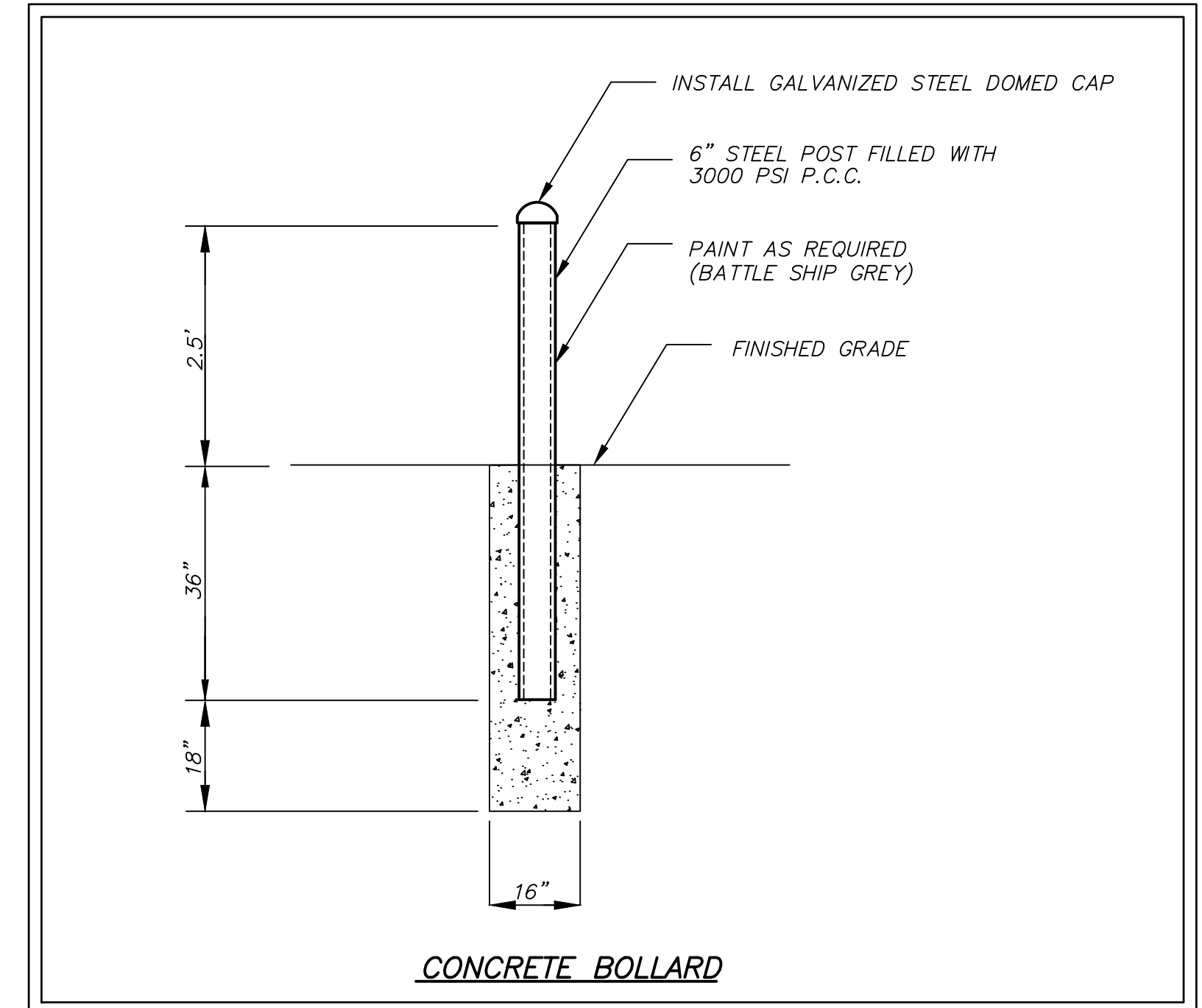
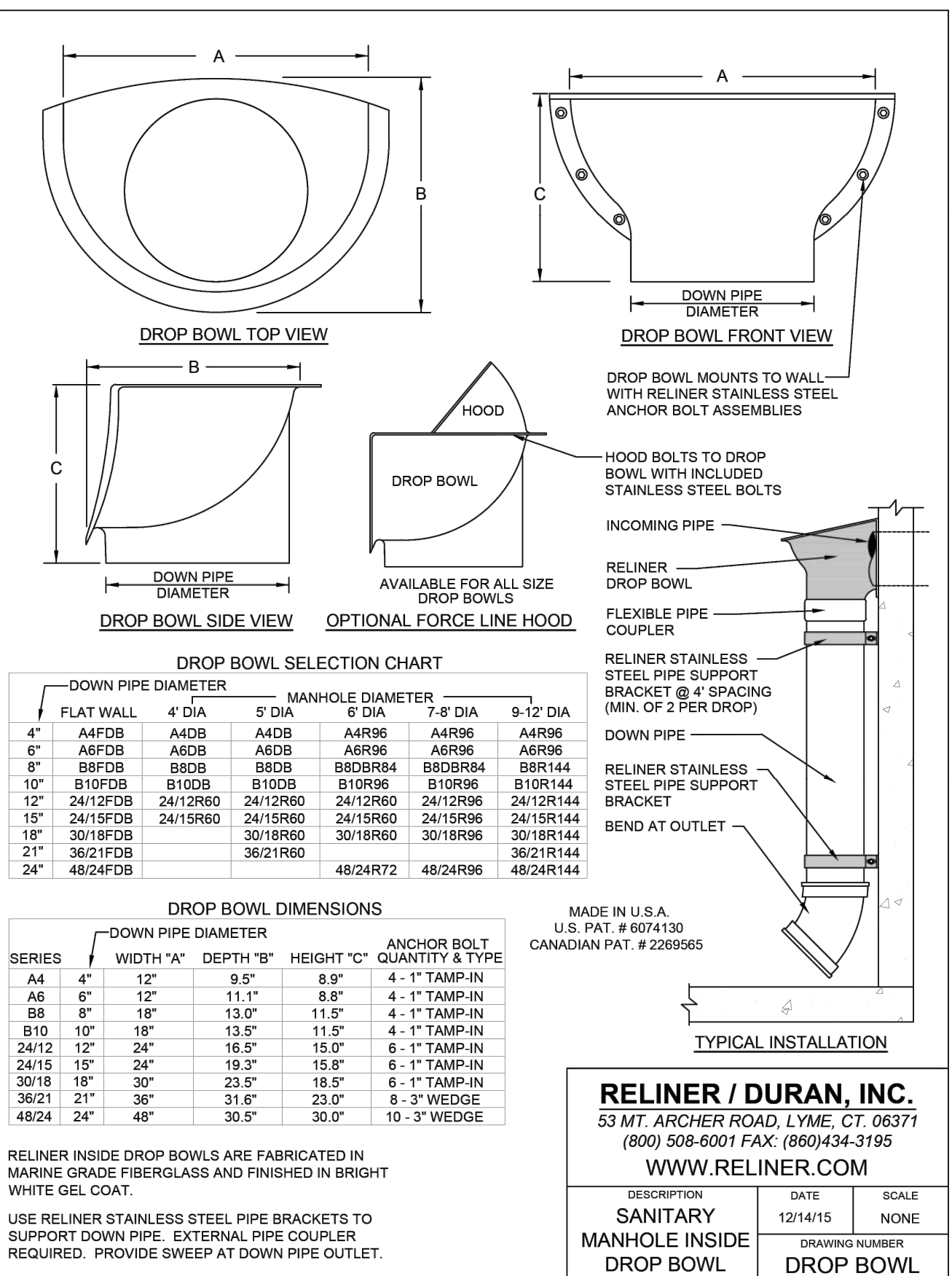
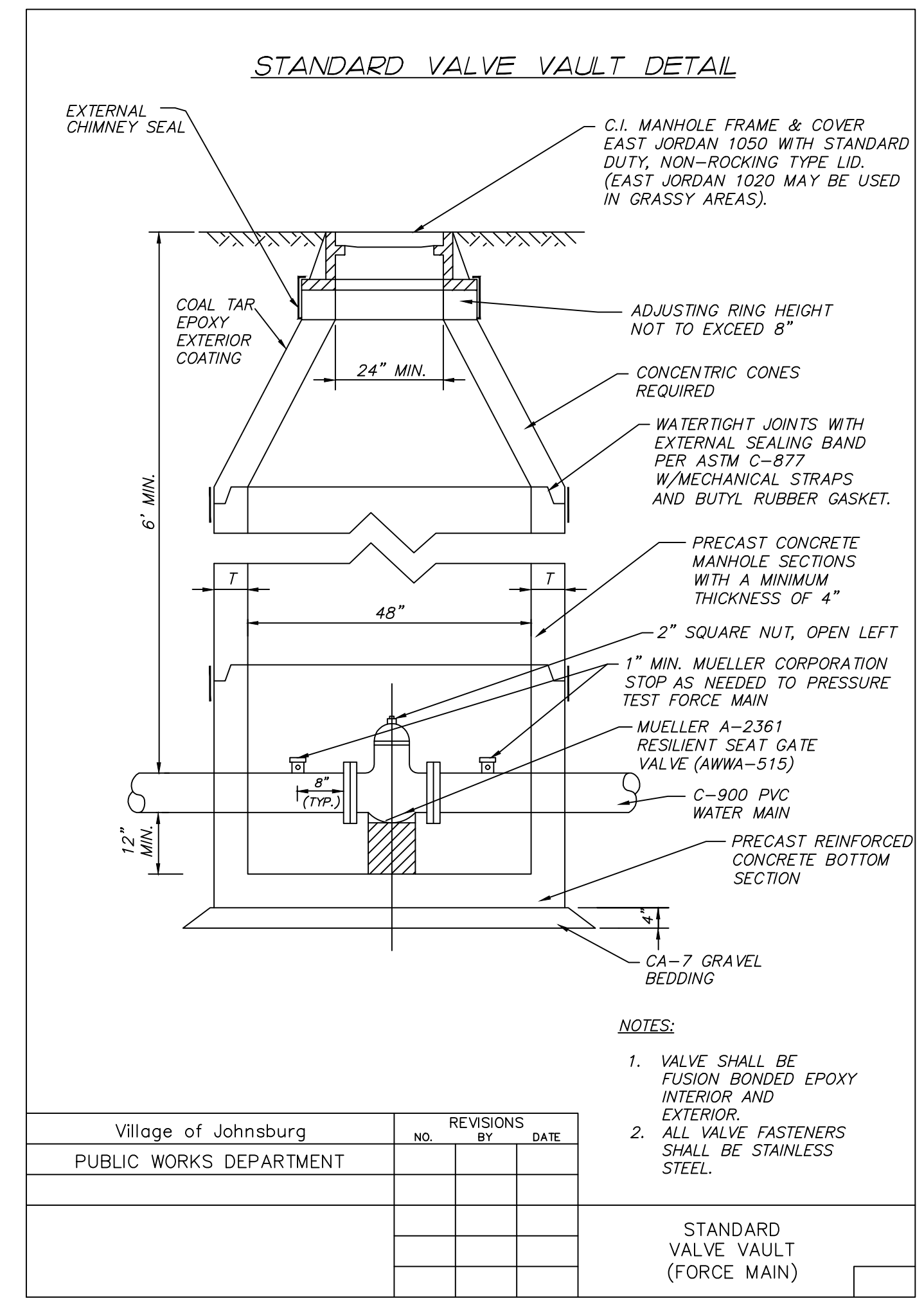
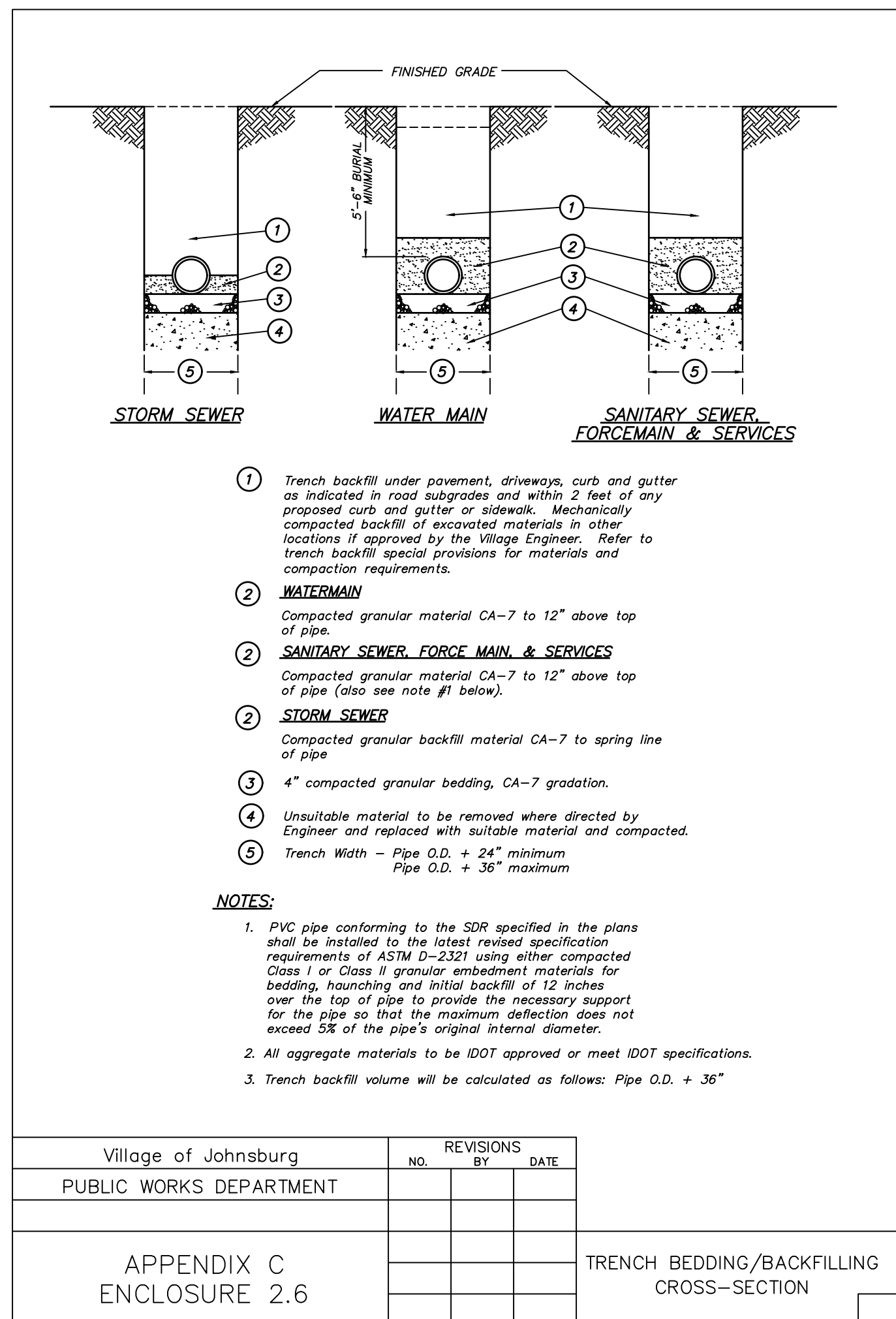
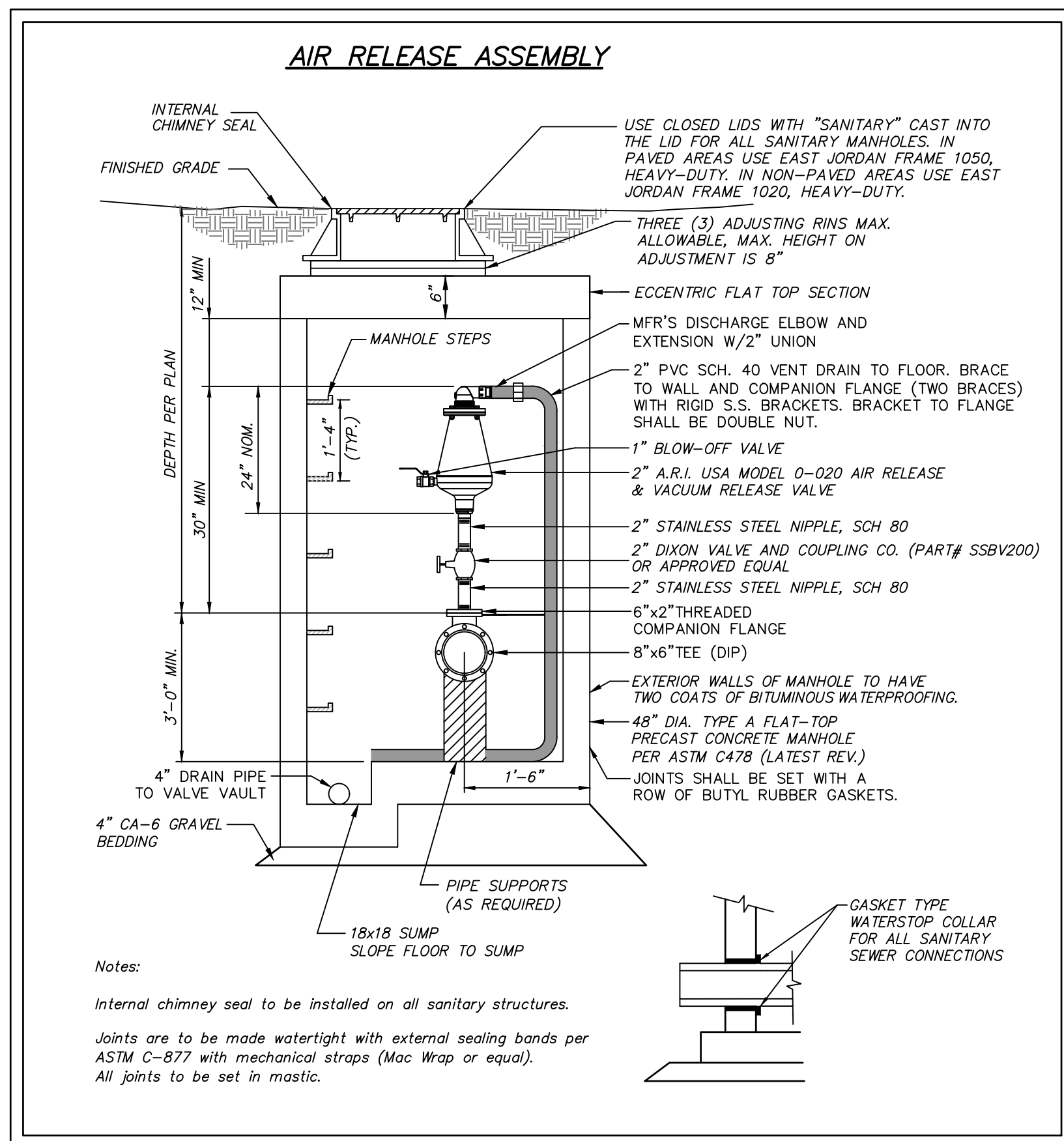

DRAWN BY: HCM JOB DATE: 2022 BAR IS ONE INCH ON OFFICIAL DRAWINGS.  
 APPROVED: SGM JOB NUMBER: 210915 0" [REDACTED] 1"  
 CAD DATE: 1/9/2024 1:44:45 PM IF NOT ONE INCH, ADJUST SCALE ACCORDINGLY.  
 CAD FILE: \\hrgreen.com\YRG\Data\2021\210915\CAD\DWG\C\210915\_CU400\_Details.dwg

NO.	DATE	BY	REVISION DESCRIPTION

ILLINOIS DESIGN FIRM # 184.001322  
 1391 CORPORATE DRIVE, SUITE 203  
 McHENRY, ILLINOIS 60050  
 PHONE: 815.385.1778 | TOLL FREE: 800.728.7805  
 FAX: 815.385.1781 | HRGreen.com

EAST SERVICE AREA PHASE 1  
 SANITARY SEWER EXTENSION  
 VILLAGE OF JOHNSBURG  
 JOHNSBURG, ILLINOIS

FOR BID  
 STANDARD DETAILS

SHEET NO.  
 CU400

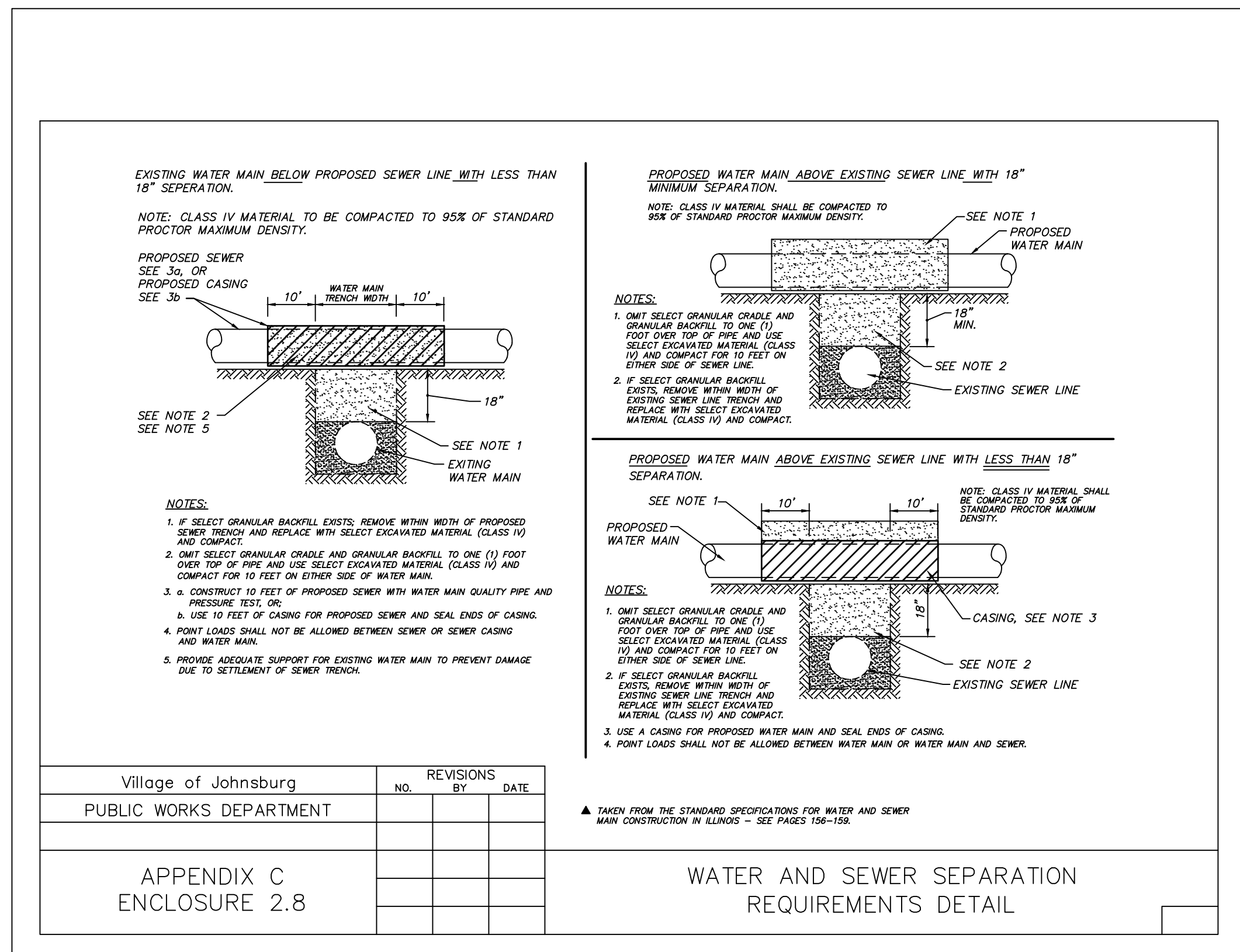
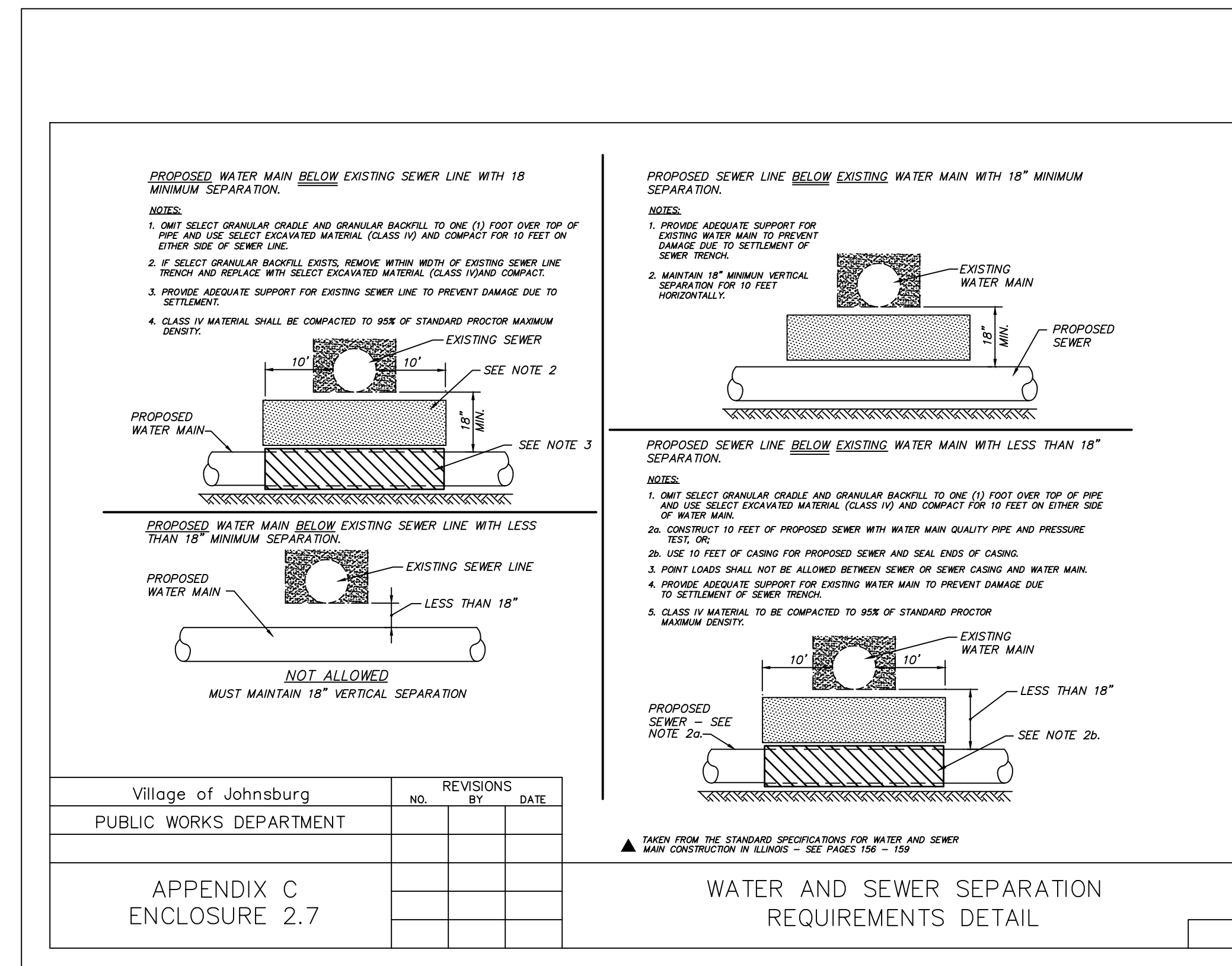
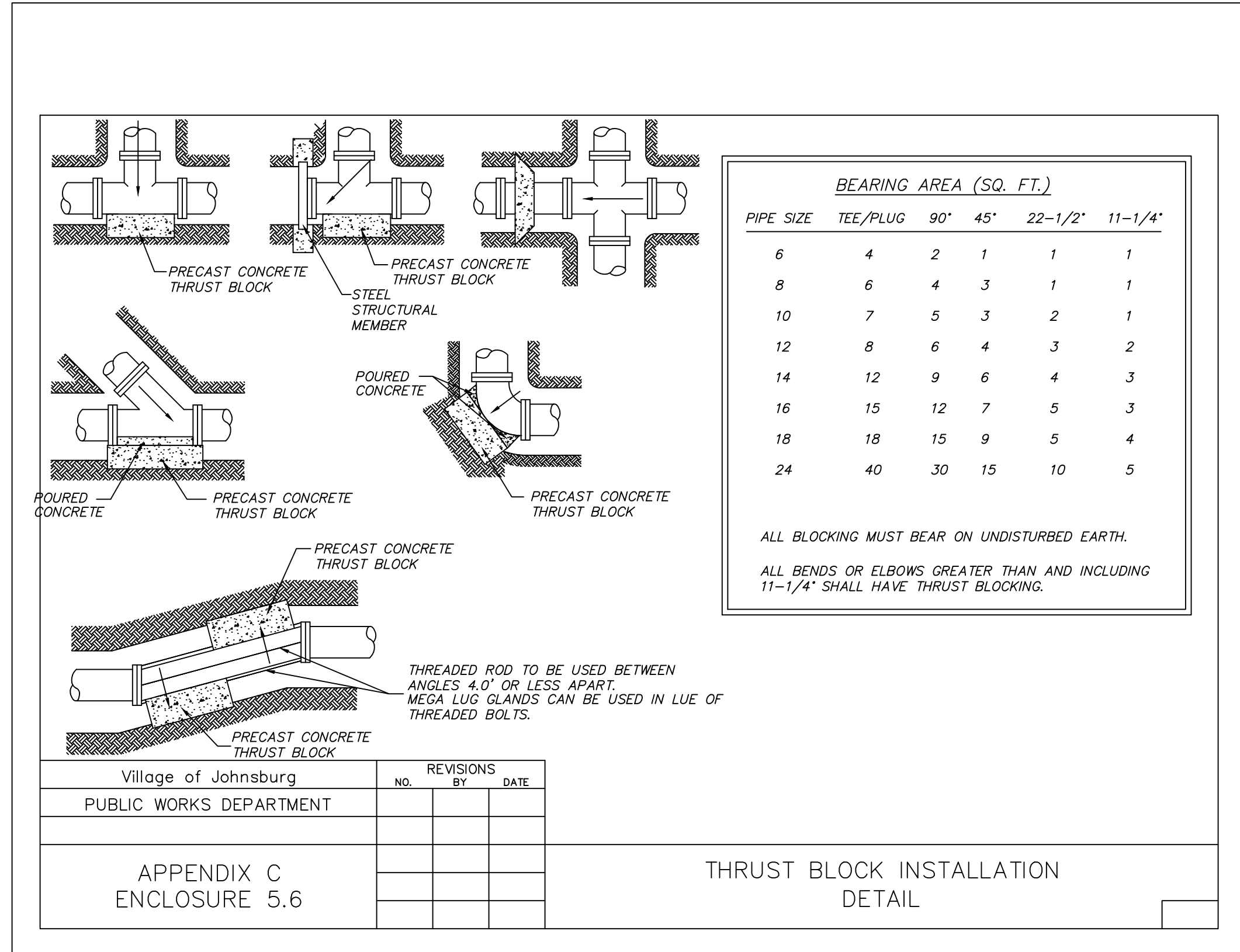
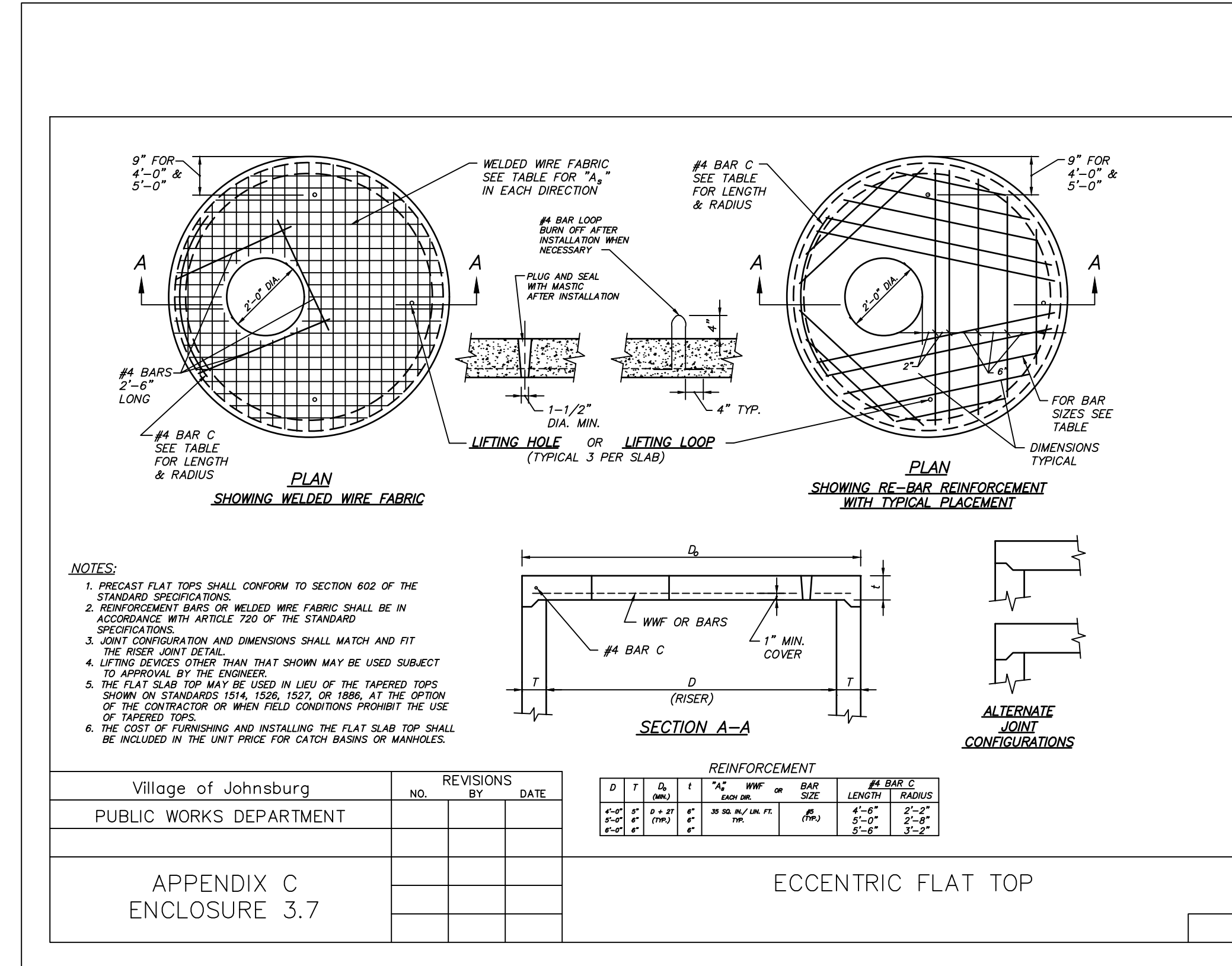
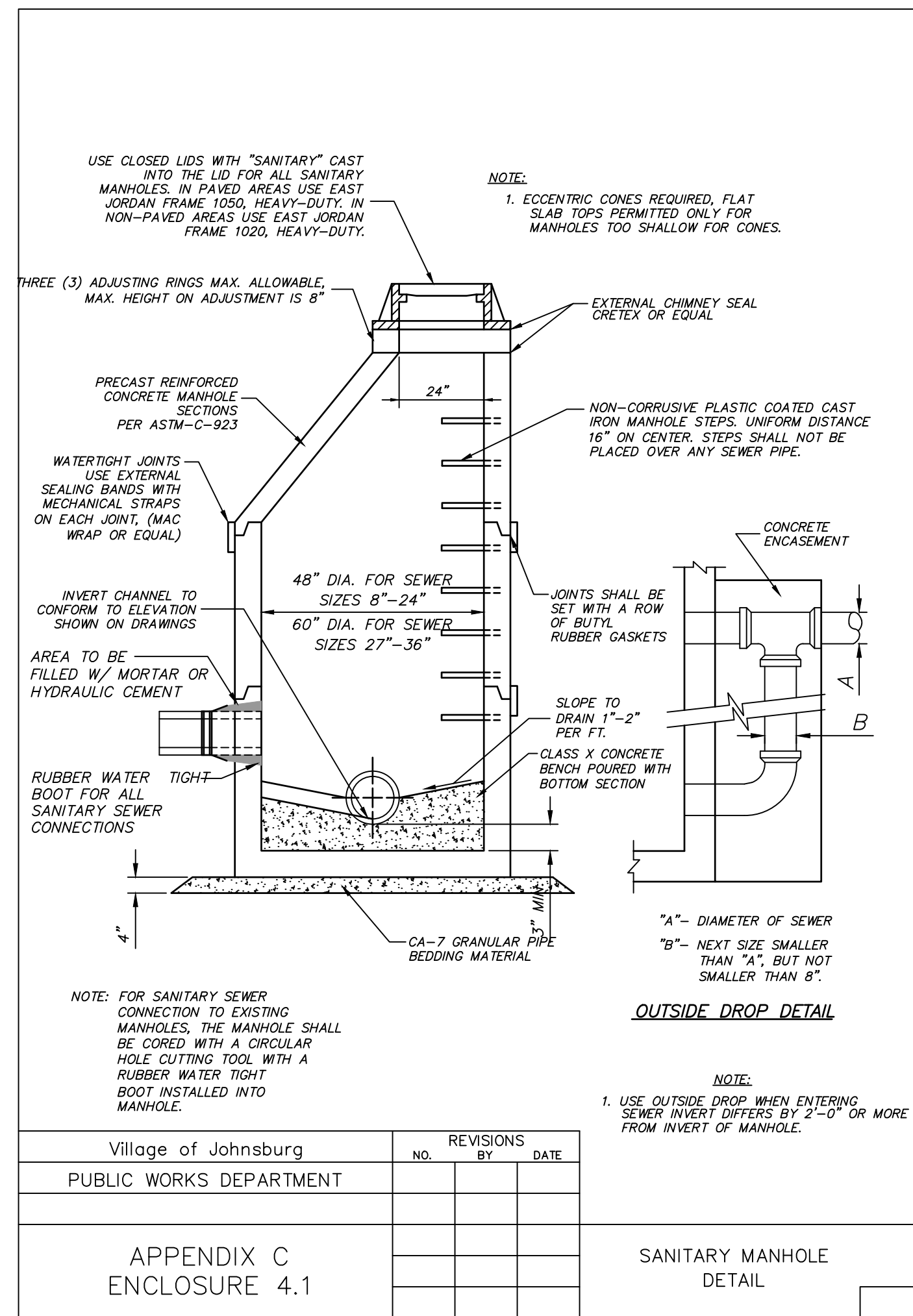

FOR BID

DRAWN BY: HCM JOB DATE: 2022 BAR IS ONE INCH ON OFFICIAL DRAWINGS.

APPROVED: SGM JOB NUMBER: 210915 0

CAD DATE: 1/9/2024 1:44:45 PM IF NOT ONE INCH, ADJUST SCALE ACCORDINGLY.

CAD FILE: \\hrgreen.com\HRG\Data\2021\210915\CAD\Dwgs\C\210915\_CU400\_Details.dwg

NO.	DATE	BY	REVISION DESCRIPTION



ILLINOIS DESIGN FIRM # 184.001322  
1391 CORPORATE DRIVE, SUITE 203  
McHENRY, ILLINOIS 60050  
PHONE: 815.385.1778 | TOLL FREE: 800.728.7805  
FAX: 815.385.1781 | HRGreen.com

EAST SERVICE AREA PHASE 1  
SANITARY SEWER EXTENSION  
VILLAGE OF JOHNSBURG  
JOHNSBURG, ILLINOIS

FOR BID  
STANDARD DETAILS

SHEET NO.  
CU401

**EXPLORATORY EXCAVATION**

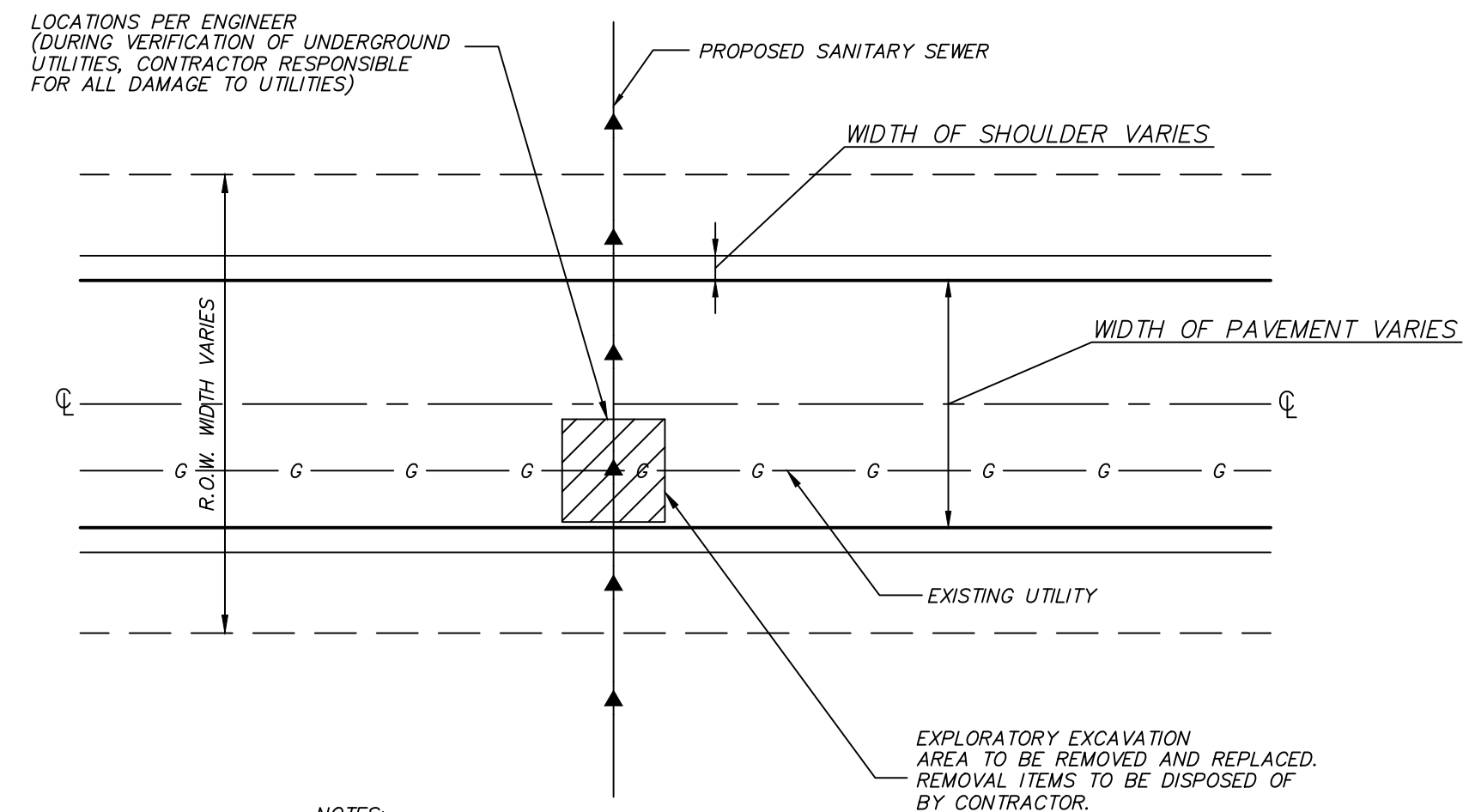

**NOTES:**

- PAVEMENT CROSS SECTIONS VARY FROM EACH ROAD, VERIFY IN FIELD AND PERFORM PAVEMENT PATCHING AS SPECIFIED IN ARTICLE 442. (MINIMUM SURFACE THICKNESS = 3" - N50, BITUMINOUS CONCRETE, MINIMUM BASE COURSE = 10" COMPACTED CA-6)
- EXPLORATORY EXCAVATION SHALL BEGIN WHEN APPROVED BY ENGINEER AND SHALL BE CONSIDERED COMPLETE WHEN UTILITY IS LOCATED OR TO SATISFACTION OF ENGINEER.

**PAVEMENT REPLACEMENT**

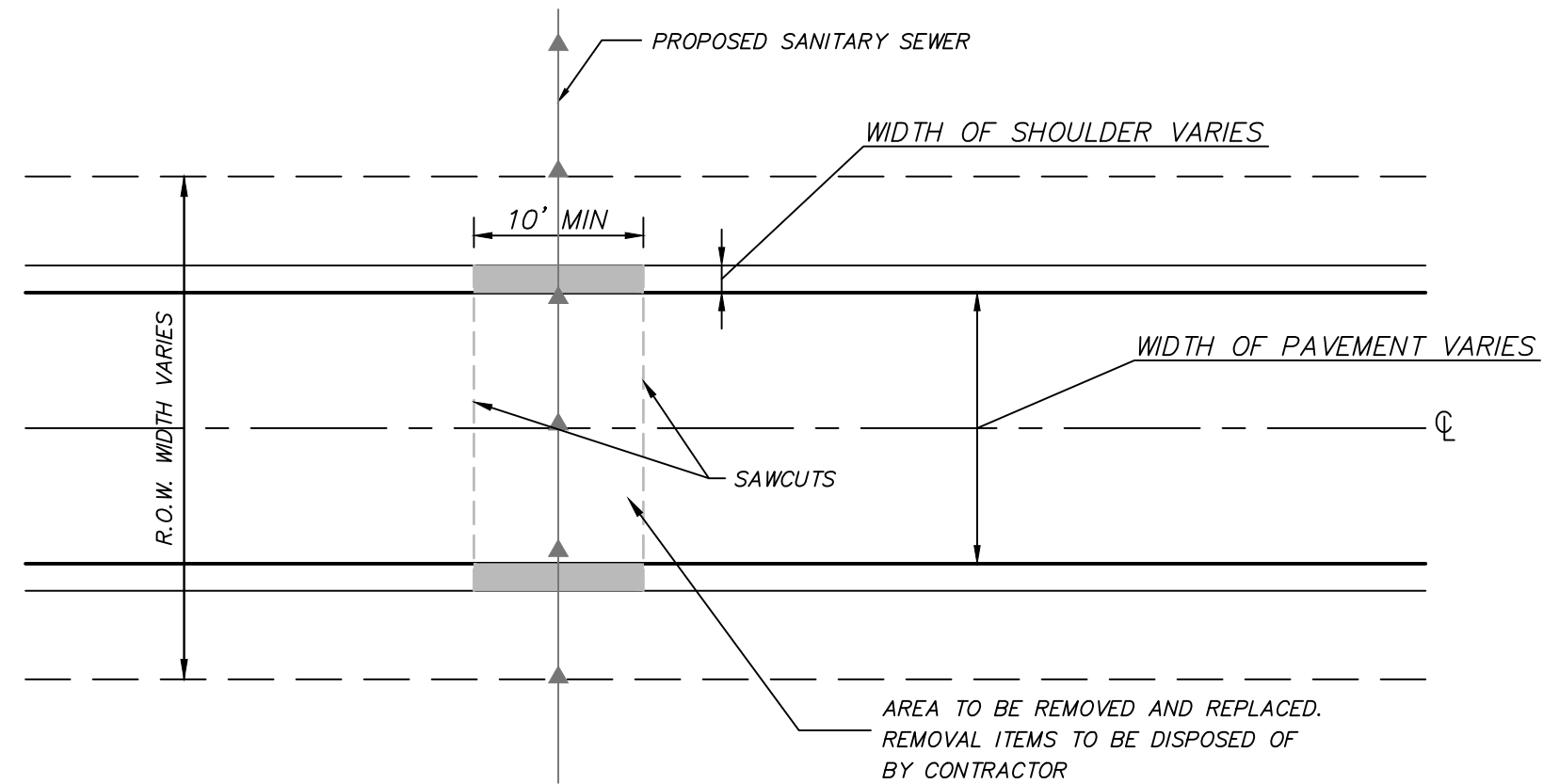

**NOTE:**

- PAVEMENT CROSS SECTIONS VARY FROM EACH ROAD, VERIFY IN FIELD AND PERFORM PAVEMENT PATCHING AS SPECIFIED IN ARTICLE 442. (MINIMUM SURFACE THICKNESS = 3" - N50, BITUMINOUS CONCRETE, MATCH EXIST.) (MINIMUM BASE COURSE = 10" COMPACTED CA-6)
- PRIME COAT - MC30

**TYPICAL AGGREGATE SHOULDER REPLACEMENT**

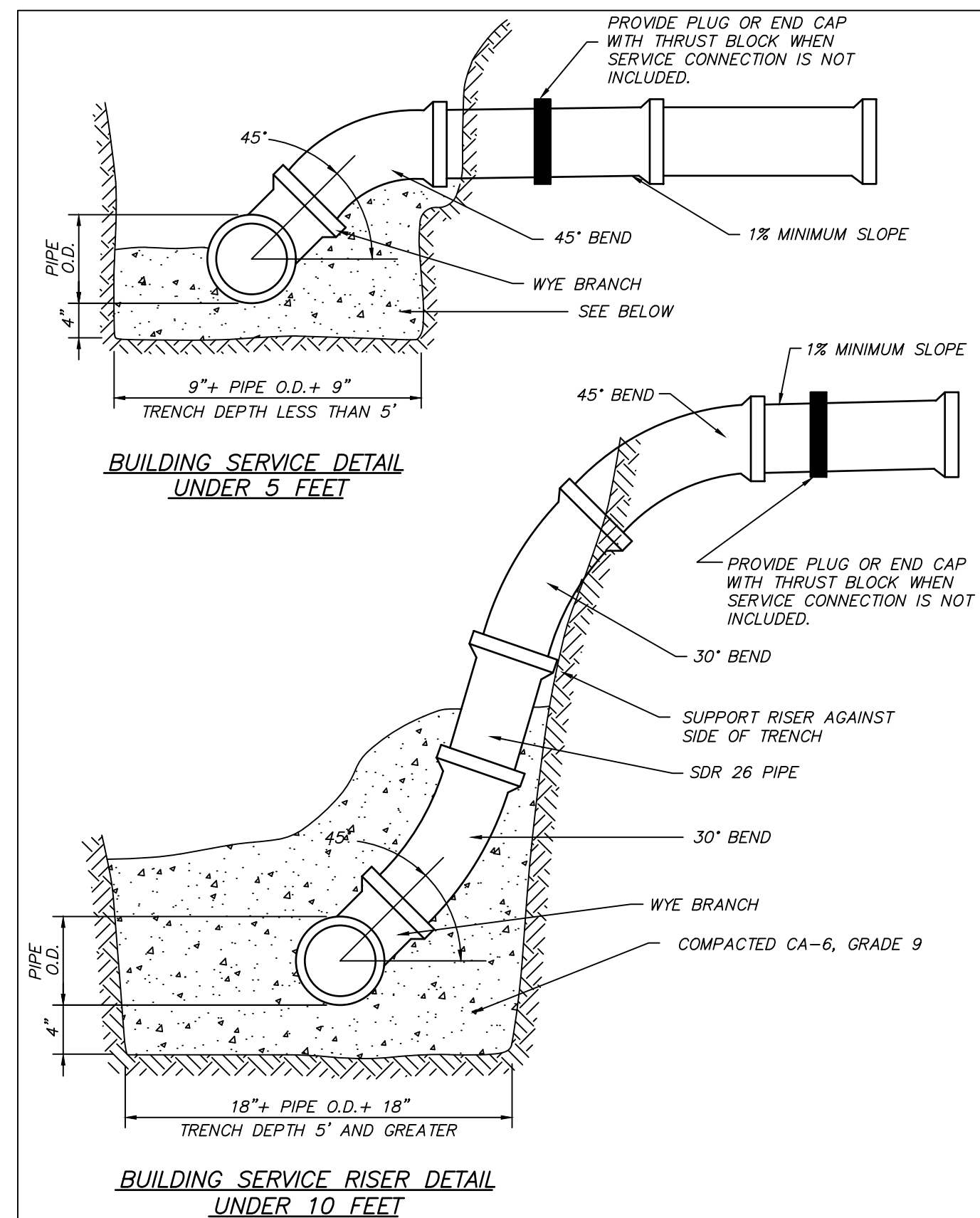
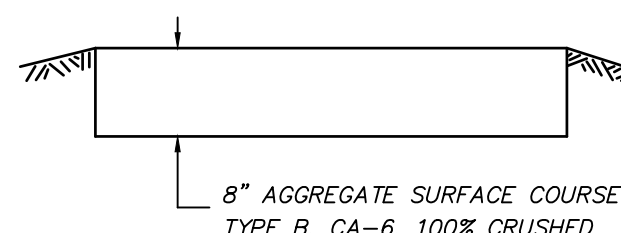

Village of Johnsburg	NO.	REVISIONS	BY	DATE
PUBLIC WORKS DEPARTMENT				
APPENDIX C ENCLOSURE 2.11		BUILDING SERVICE RISER DETAIL		

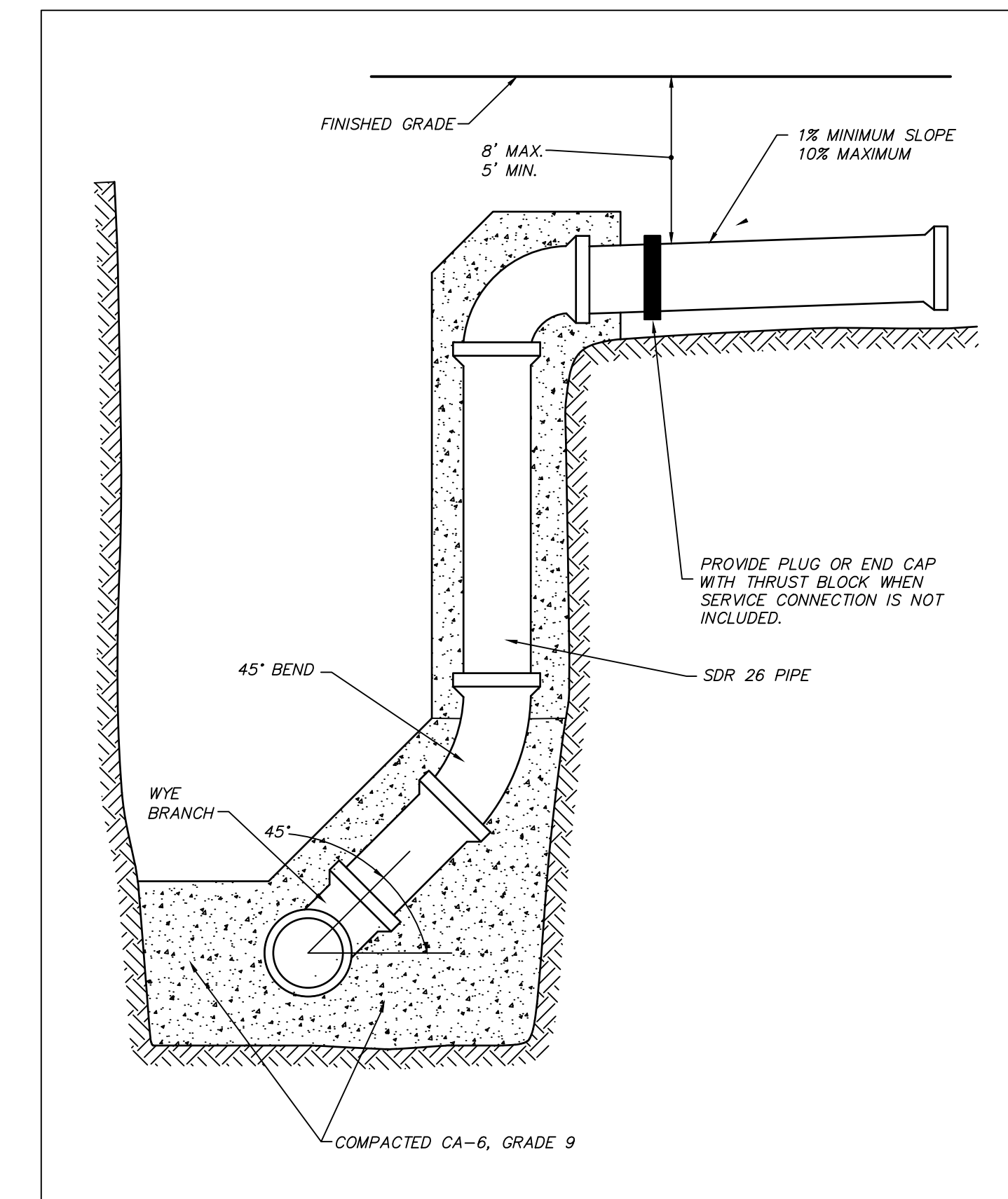

Village of Johnsburg	NO.	REVISIONS	BY	DATE
PUBLIC WORKS DEPARTMENT	1		MDJ	10/17/05
	2		MRJ	10/26/05
APPENDIX C ENCLOSURE 2.10		BUILDING SERVICE RISER DETAIL OVER 10 FEET		

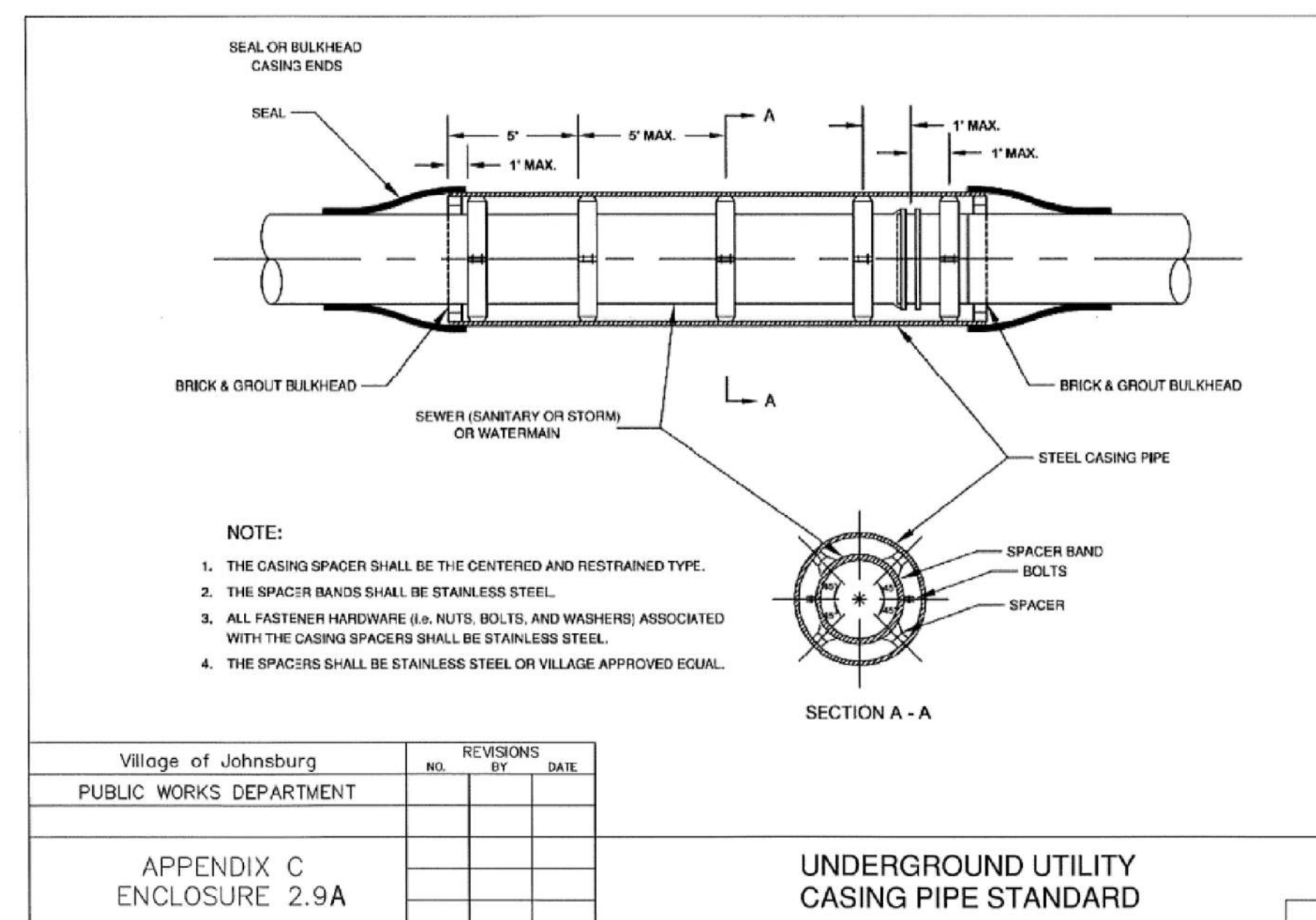

Village of Johnsburg	NO.	REVISIONS	BY	DATE
PUBLIC WORKS DEPARTMENT				
APPENDIX C ENCLOSURE 2.9A		UNDERGROUND UTILITY CASING PIPE STANDARD		

FOR BID

DRAWN BY: HCM JOB DATE: 2022  
 APPROVED: SGM JOB NUMBER: 210915  
 CAD DATE: 1/9/2024 1:44:45 PM  
 CAD FILE: \\hrgreen.com\HRG\Data\2021\210915\CAD\Dwgs\C\210915\_CU400\_Details.dwg

NO.	DATE	BY	REVISION DESCRIPTION



ILLINOIS DESIGN FIRM # 184.001322  
 1391 CORPORATE DRIVE, SUITE 203  
 McHENRY, ILLINOIS 60050  
 PHONE: 815.385.1778 | TOLL FREE: 800.728.7805  
 FAX: 815.385.1781 | HRGreen.com

EAST SERVICE AREA PHASE 1  
 SANITARY SEWER EXTENSION  
 VILLAGE OF JOHNSBURG  
 JOHNSBURG, ILLINOIS

FOR BID  
 STANDARD DETAILS

SHEET NO.  
 CU402

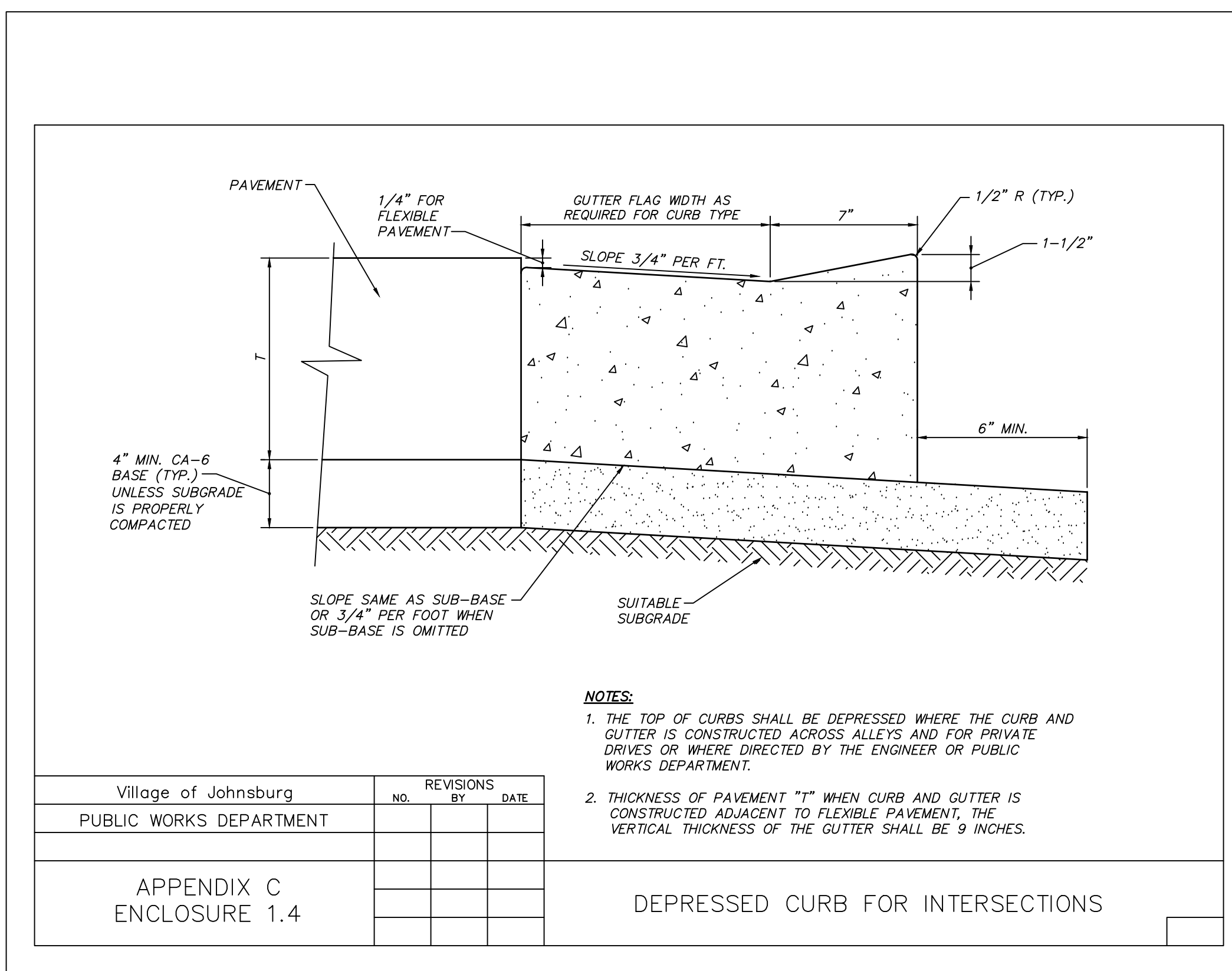
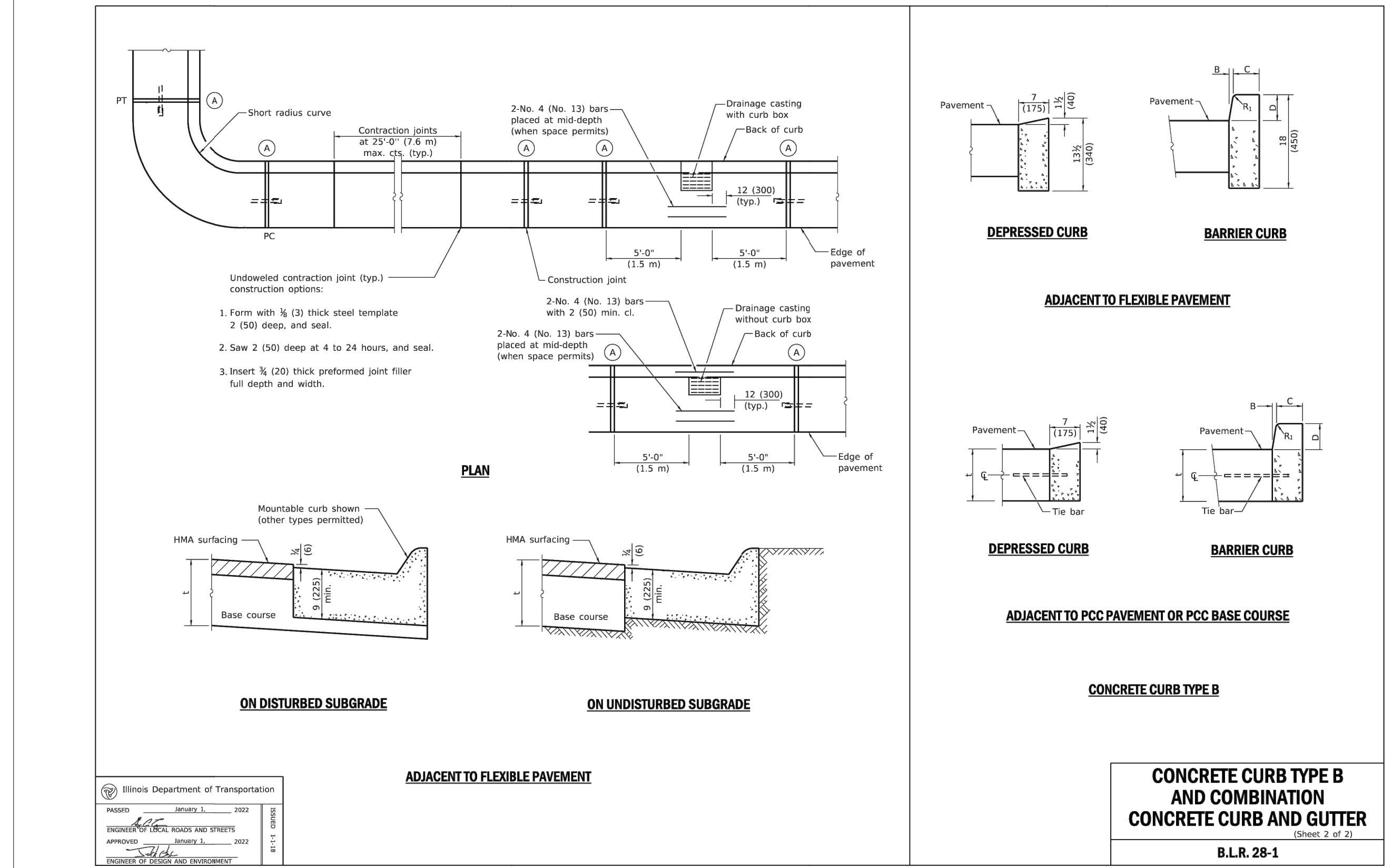
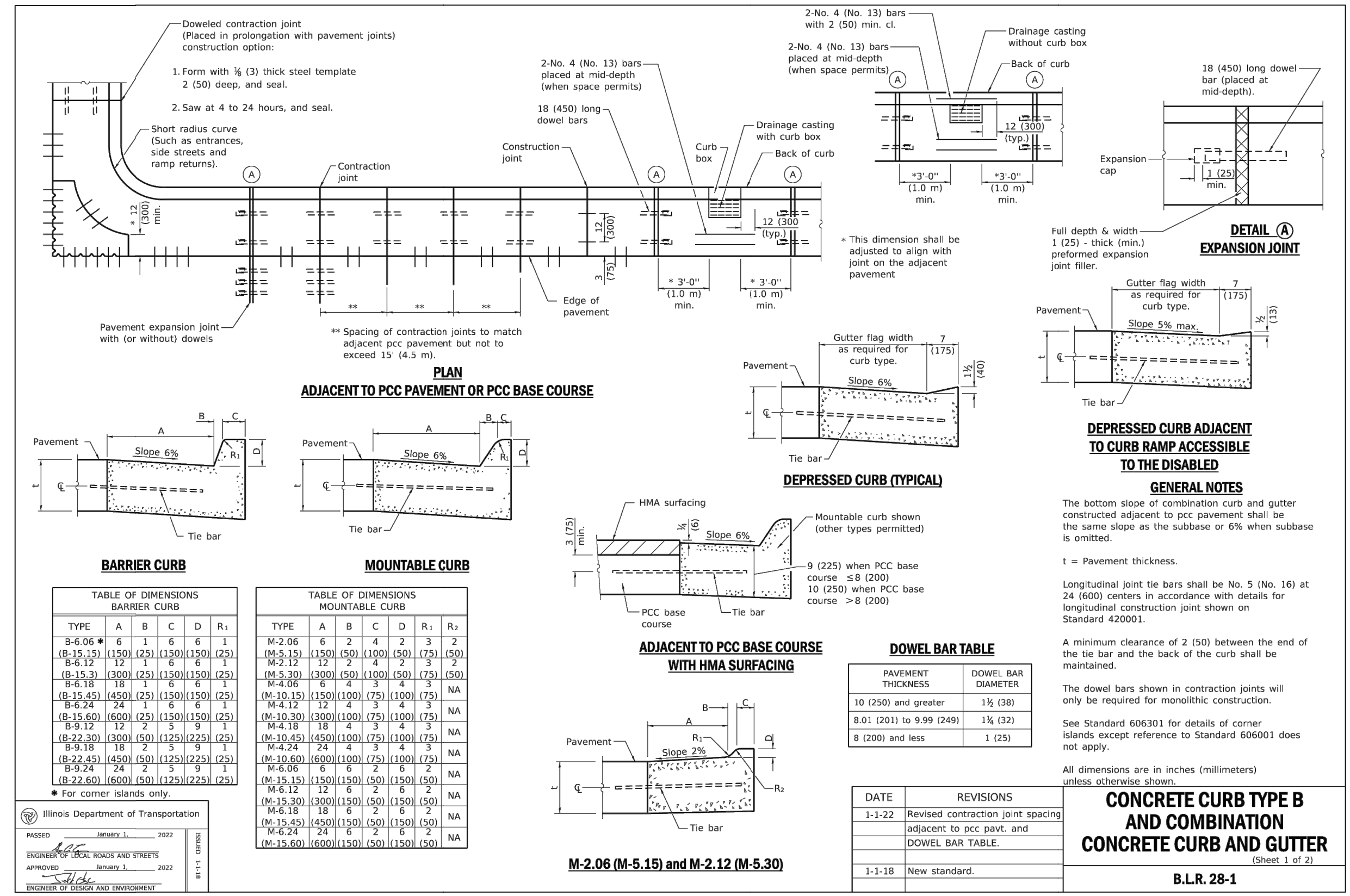

Xref: xgl-1-df01

DRAWN BY: HCM	JOB DATE: 2022	BAR IS ONE INCH ON OFFICIAL DRAWINGS.
APPROVED: SGM	JOB NUMBER: 210915	0
CAD DATE: 1/9/2024 1:44:45 PM		IF NOT ONE INCH, ADJUST SCALE ACCORDINGLY.
CAD FILE: \\hrgreen.com\HRG\Data\2021\210915\CAD\Dwgs\C\210915_CU400_Details.dwg		

NO.	DATE	BY	REVISION DESCRIPTION

**HRGreen**

ILLINOIS DESIGN FIRM # 184.001322  
1391 CORPORATE DRIVE, SUITE 203  
MCHENRY, ILLINOIS 60050  
PHONE: 815.385.1778 | TOLL FREE: 800.728.7805  
FAX: 815.385.1781 | HRGreen.com

EAST SERVICE AREA PHASE 1  
SANITARY SEWER EXTENSION  
VILLAGE OF JOHNSBURG  
JOHNSBURG, ILLINOIS

FOR BID  
STANDARD DETAILS

SHEET NO.  
**CU403**

FOR BID

**SLOPE INSTALLATION**

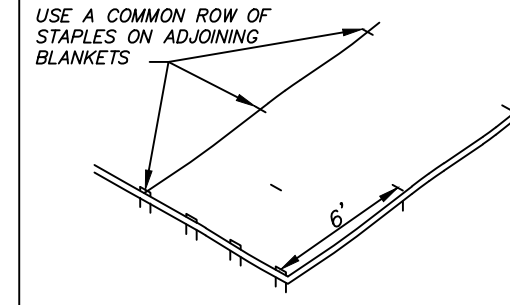

USE 4 STAPLES ACROSS AT THE START OF EACH ROLL AND CONTINUE TO STAPLE THROUGHOUT THE LENGTH OF THE ROLL AT 4 FT. INTERVALS.

**DITCH LINER**

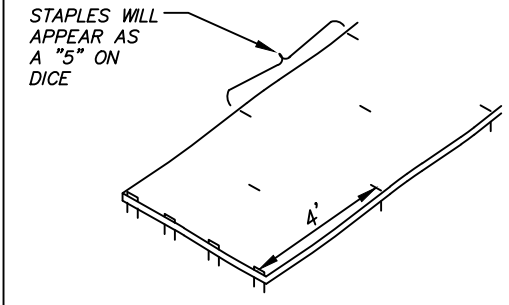

USE 4 STAPLES ACROSS AT THE START OF EACH ROLL AND CONTINUE TO STAPLE THROUGHOUT THE LENGTH OF THE ROLL AT 4 FT. INTERVALS.

**ROLL SIZE**  
 WIDTH . . . . . 48 IN. (+/- 1 IN.)  
 LENGTH . . . . . 180 FT. AVERAGE  
 WEIGHT PER ROLL . . . . . 78 lbs. (+/- 10%)  
 SQUARE YARDS PER ROLL . . . . . 80 AVERAGE

**INSTALLATION INSTRUCTIONS:**

PROPERLY PREPARE, FERTILIZE AND SEED AREA TO BE COVERED BEFORE BLANKET IS APPLIED. WHEN THE BLANKET IS UNROLLED, NETTING SHOULD BE ON TOP AND FIBERS IN CONTACT WITH THE SOIL OVER THE ENTIRE AREA. IN DITCHES, APPLY BLANKETS IN THE DIRECTION THE WATER FLOWS, BUTTING THEM AT THE ENDS AND SIDES AND THEN STAPLING. ON SLOPES, APPLY BLANKETS EITHER HORIZONTALLY OR VERTICALLY TO SLOPE, BUTT ENDS AND SIDES AND THEN STAPLE. IT IS NOT NECESSARY TO DIG CHECK SLOTS. ANCHOR DITCHES OR BURY ENDS OF BLANKETS UNLESS CALLED FOR IN DESIGN SPECIFICATIONS.

**STAPLING INSTRUCTIONS FOR AMXCO CURLEX BLANKETS:**

USE WIRE STAPLES .091" IN DIAMETER OR GREATER, "U" SHAPED WITH LEGS 6" IN LENGTH AND A 1" CROWN. SIZE AND GAUGE OF STAPLES USED WILL VARY WITH SOIL CONDITIONS. DRIVE STAPLES VERTICALLY INTO THE GROUND. USE FOUR STAPLES ACROSS AT THE START OF EACH ROLL. FOR SLOPE INSTALLATION, CONTINUE TO STAPLE ALONG THE LENGTH OF THE ROLL AT 4 FT. INTERVALS. FOR DITCH LINER, STAPLE ALONG THE LENGTH OF THE ROLL AT 4 FT. INTERVALS. ANOTHER ROW OF STAPLES IN THE CENTER OF EACH BLANKET SHOULD BE ALTERNATELY SPACED BETWEEN EACH SIDE FOR EITHER SLOPE OR DITCH. USE A COMMON ROW OF STAPLES ON ADJOINING BLANKETS.

Village of Johnsburg	NO.	REVISIONS BY	DATE
PUBLIC WORKS DEPARTMENT			
APPENDIX C ENCLOSURE 3.12			

EXCELSIOR BLANKET INSTALLATION DETAIL

**MAINTENANCE**

- Filter barriers shall be inspected immediately after each rainfall and at least daily during prolonged rainfall. Any required repairs shall be made immediately.
- Should the fabric decompose or become ineffective prior to the end of the expected usable life and the barrier still be necessary, the fabric shall be replaced promptly.
- Sediment deposits should be removed after each storm event. They must be removed when deposits reach approximately half the height of the barrier.
- Any sediment deposits remaining in place after the silt fence or filter barrier is no longer required shall be dressed to conform with the existing grade, prepared and seeded.

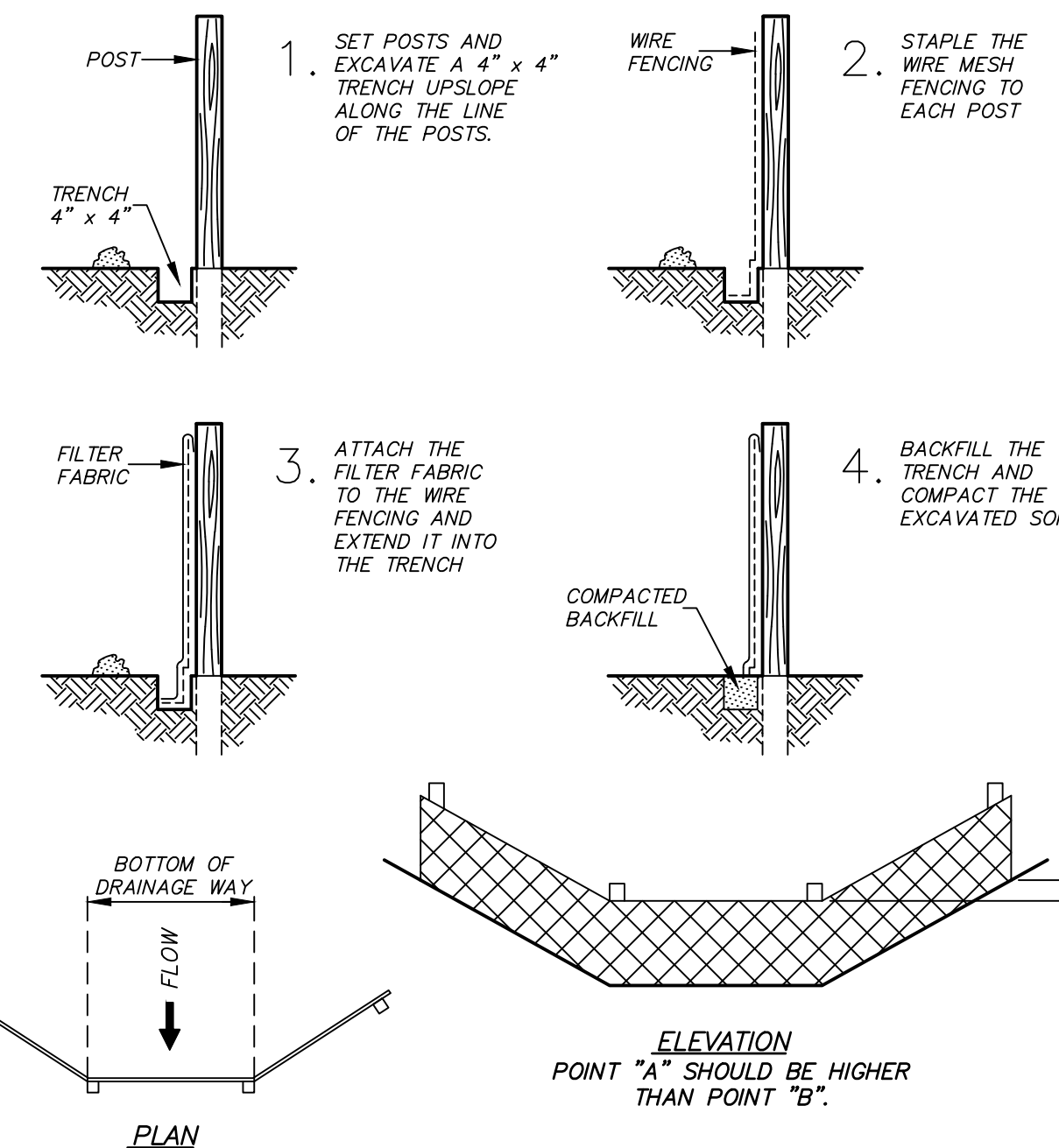

Village of Johnsburg	NO.	REVISIONS BY	DATE
PUBLIC WORKS DEPARTMENT			
APPENDIX C ENCLOSURE 3.10			

TEMPORARY SILTATION FENCE DETAIL

**INLET FILTER BASKET ASSEMBLY (OR APPROVED EQUAL)**

**1. IDENTIFY YOUR FRAME STYLE, SIZE, AND MATERIAL**

STYLE	FRAME STYLE AND SIZE	Frame P/N
ROUND	Small Round (up to 20" diameter) (A) Rim	620RD
	Med Round (20.1" - 26" dia grates) (A) up to 21" dia openings (B)	620RD
	Large Round (26.1" - 32" dia grates) (A) up to 30" openings (B)	620RD
	X-Large Round (32.1" - 38" dia grates) (A) up to 37" dia openings (B)	620RD
RECT	Small Rect / Square (up to 30" dia) (A) up to 30" openings (B)	620RS
	Med Rect / Square (up to 36" dia) (A) up to 36" openings (B)	620RS
	Large Rect / Square (up to 42" dia) (A) up to 42" openings (B)	620RS
	X-Large Rect / Square (up to 48" dia) (A) up to 48" openings (B)	620RS
CORNER	Small Rect / Square (up to 30" dia) (A) up to 30" openings (B)	620SC
	Med Rect / Square (up to 36" dia) (A) up to 36" openings (B)	620SC
	Large Rect / Square (up to 42" dia) (A) up to 42" openings (B)	620SC
	X-Large Rect / Square (up to 48" dia) (A) up to 48" openings (B)	620SC
WALL MOUNT	12" diameter Hyplast castings (Stainless Steel Framing standard)	62212W
	18" diameter Hyplast castings (Stainless Steel Framing standard)	62218W
	24" diameter Hyplast castings (Stainless Steel Framing standard)	62224W
	30" diameter Hyplast castings (Stainless Steel Framing standard)	62230W

**2. SELECT YOUR FILTER BAG PART NUMBER**

FLEXSTORM FILTER BAGS	(27" depth) STD Bag P/N	(12" depth) Short Bag P/N	Clean Water Flow Rate (GPM/SqFt)	Min A.O.S. (15' Service)
FX Standard Woven Bag	FX	FX-S	200	40"
FX+ Woven w/ MyCels	FXP	FXP-S	200	40"
FXD Woven w/ OI Boom	FXD	FXD-S	200	40"
PC Post Construction Bag	PC	PC-S	137	140"
PC+ PC Bag w/ MyCels	PCP	PCP-S	137	140"
LL Litter and Leaf Bag	LL	LL-S	137	35"
LL+DOT Non-Woven Bag	LL	LL-S	145	70"

**3. CREATE YOUR FLEXSTORM INLET FILTER PART NUMBER**

Frame P/N from Step 1. Filter Bag P/N from Step 2. Framing Material

**STORM INLET FILTER BAG NOTES:**

- DURING CONSTRUCTION, CONTRACTOR SHALL INSTALL "FLEXSTORM" (OR EQUAL) (STANDARD) FX-STYLE SEDIMENT FILTER BAGS IN ALL OPEN GRATE STORM MANHOLES. THE "FLEXSTORM" FILTER INSERTS SHALL BE INSTALLED AND MAINTAINED PURSUANT TO MANUFACTURER SPECIFICATIONS.
- POST CONSTRUCTION, CONTRACTOR SHALL INSTALL "FLEXSTORM" (OR EQUAL) (STANDARD) PC-STYLE SEDIMENT FILTER BAGS IN ALL OPEN GRATE STORM MANHOLES. THE "FLEXSTORM" FILTER INSERTS SHALL BE INSTALLED AND MAINTAINED PURSUANT TO MANUFACTURER SPECIFICATIONS.

FOR BID

DRAWN BY: HCM JOB DATE: 2022 BAR IS ONE INCH ON OFFICIAL DRAWINGS.  
 APPROVED: SGM JOB NUMBER: 210915 0  
 CAD DATE: 1/9/2024 1:44:45 PM IF NOT ONE INCH, ADJUST SCALE ACCORDINGLY.  
 CAD FILE: \\hrgreen.com\HRG\Data\2021\210915\CAD\Dwgs\C\210915\_CU400\_Details.dwg

NO.	DATE	BY	REVISION DESCRIPTION

ILLINOIS DESIGN FIRM # 184.001322  
 1391 CORPORATE DRIVE, SUITE 203  
 McHENRY, ILLINOIS 60050  
 PHONE: 815.385.1778 | TOLL FREE: 800.728.7805  
 FAX: 815.385.1781 | HRGreen.com

EAST SERVICE AREA PHASE 1  
 SANITARY SEWER EXTENSION  
 VILLAGE OF JOHNSBURG  
 JOHNSBURG, ILLINOIS

FOR BID  
 STANDARD DETAILS

SHEET NO.  
 CU404

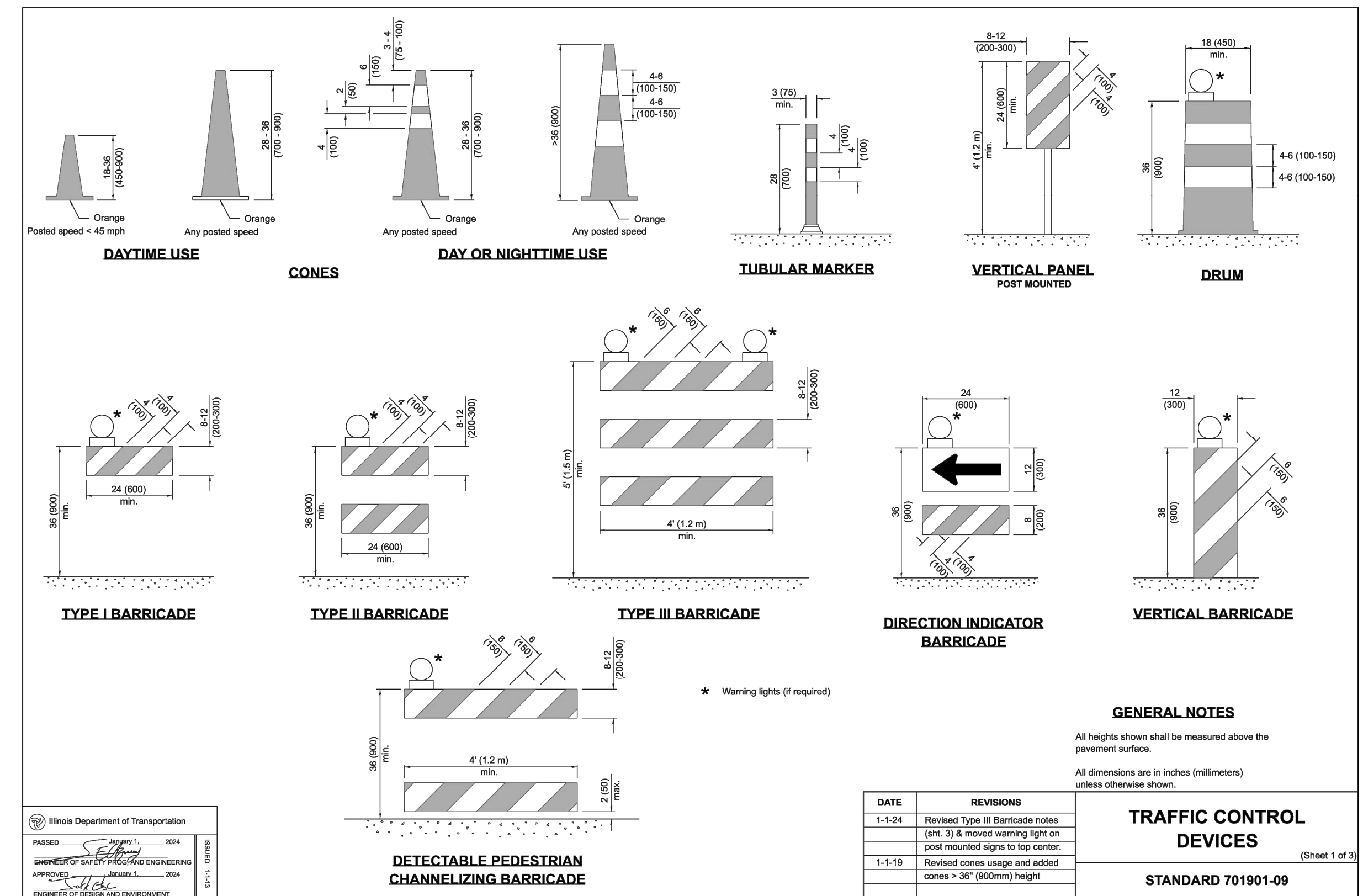
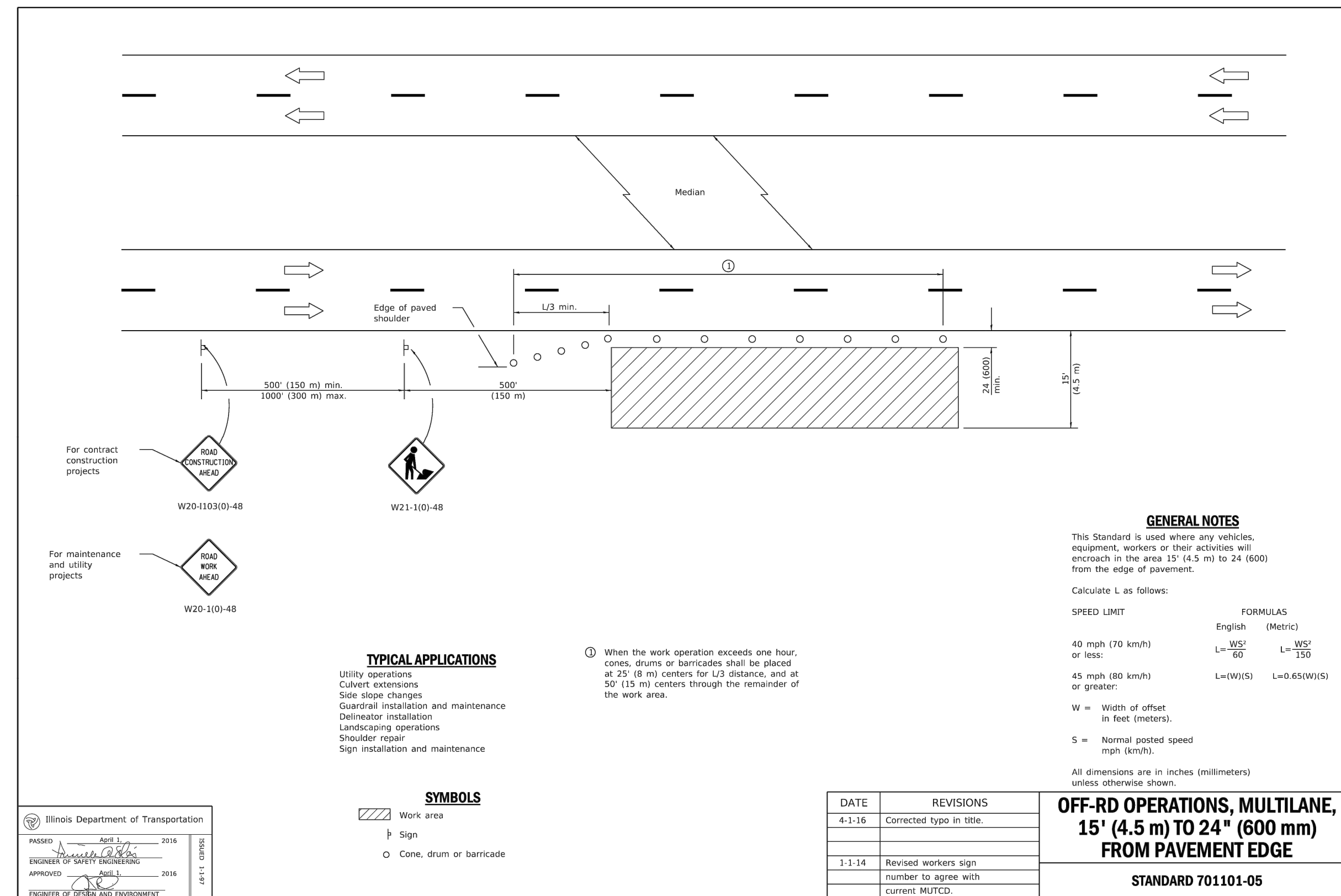

FOR BID

DRAWN BY: HCM JOB DATE: 2022  
 APPROVED: SGM JOB NUMBER: 210915  
 CAD DATE: 1/9/2024 1:44:45 PM  
 CAD FILE: \\hrgreen.com\HRG\Data\2021\210915\CAD\Dwgs\C\210915\_CU400\_Details.dwg

BAR IS ONE INCH ON OFFICIAL DRAWINGS.  
 IF NOT ONE INCH, ADJUST SCALE ACCORDINGLY.

NO.	DATE	BY	REVISION DESCRIPTION

**HRGreen**  
 ILLINOIS DESIGN FIRM # 184.001322  
 1391 CORPORATE DRIVE, SUITE 203  
 McHENRY, ILLINOIS 60050  
 PHONE: 815.385.1778 | TOLL FREE: 800.728.7805  
 FAX: 815.385.1781 | HRGreen.com

EAST SERVICE AREA PHASE 1  
 SANITARY SEWER EXTENSION  
 VILLAGE OF JOHNSBURG  
 JOHNSBURG, ILLINOIS

FOR BID  
 STANDARD DETAILS

SHEET NO.  
**CU405**

Xref: xgt-1-dwg